

TOSHIBA PHOTOCOUPLER GaAs IRED & PHOTO-TRANSISTOR

## TLP627, TLP627-2, TLP627-4

Unit in mm

PROGRAMMABLE CONTROLLERS  
DC-OUTPUT MODULE  
TELECOMMUNICATION

The TOSHIBA TLP627,-2 and -4 consists of a gallium arsenide infrared emitting diode optically coupled to a darlington connected phototransistor which has an integral base-emitter resistor to optimize switching speed and elevated temperature characteristics.

The TLP627-2 offers two isolated channels in a eight lead plastic DIP, while the TLP627-4 provide four isolated channels per package.

- Collector-Emitter Voltage : 300V(Min)
- Current Transfer Ratio : 1000%(Min)
- Isolation Voltage : 5000Vrms(Min)
- UL Recognized : UL1577, File No.E67349

	MADE IN JAPAN	MADE IN THAILAND
UL Recognized	E67349 *1	E152349 *1
BSI Approved	7426, 7427 *2	7426, 7427 *2

\*1 UL1577

\*2 BS EN60065: 2002, BS EN60950-1: 2002

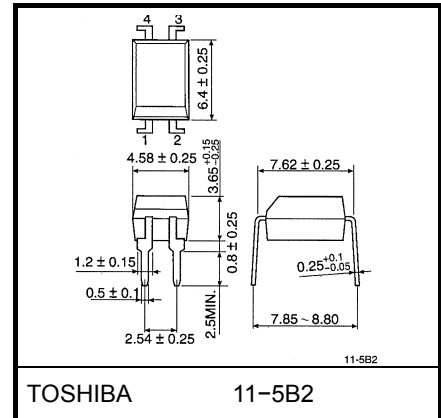

Weight: 0.26 g

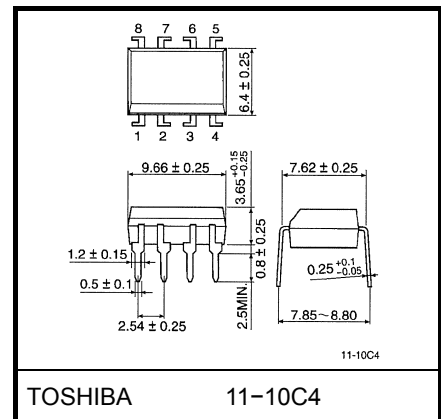

Weight: 0.54 g

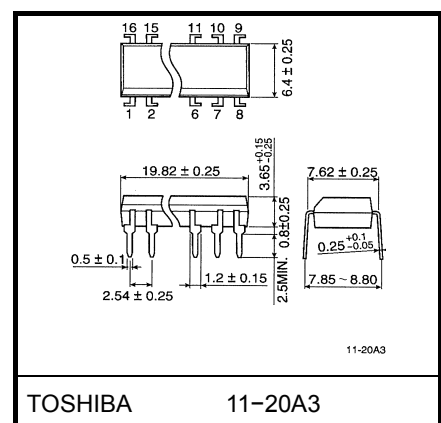

Weight: 1.1 g

### PIN CONFIGURATION (TOP VIEW)

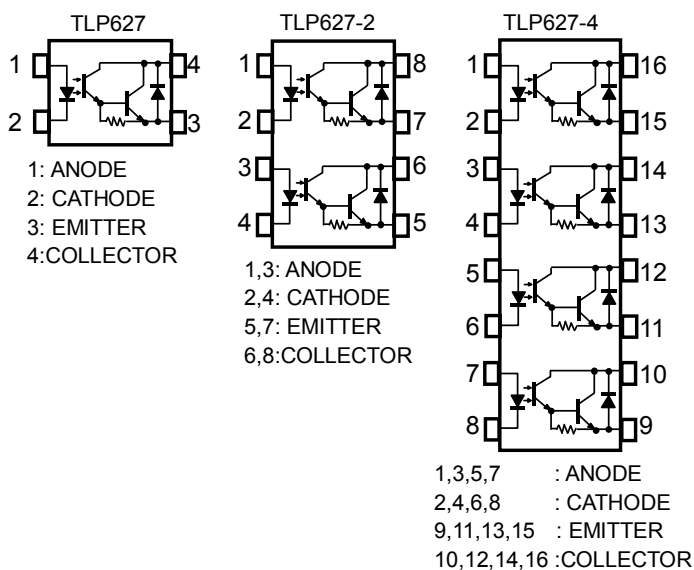

## Absolute Maximum Ratings (Ta=25°C)

CHARACTERISTIC		SYMBOL	RATING		UNIT
			TLP627	TLP627-2 TLP627-4	
LED	Forward Current	$I_F$	60	50	mA
	Forward Current Derating	$\Delta I_F / ^\circ\text{C}$	-0.7(Ta $\geq$ 39°C)	-0.5(Ta $\geq$ 25°C)	mA / °C
	Pulse Forward Current	$I_{FP}$	1(100 $\mu$ s pulse, 100pps)		A
	Power Dissipation (1 Circuit)	$P_D$	100	70	mW
	Power Dissipation Derating (Ta $\geq$ 25°C, 1 Circuit)	$\Delta P_D / ^\circ\text{C}$	-1.0	-0.7	mW / °C
	Reverse Voltage	$V_R$	5		V
	Junction Temperature	$T_j$	125		°C
DETECTOR	Collector-Emitter Voltage	$V_{CEO}$	300		V
	Emitter -Collector Voltage	$V_{ECO}$	0.3		V
	Collector Current	$I_C$	150		mA
	Collector Power Dissipation (1 Circuit)	$P_C$	150(*300)	100	mW
	Collector Power Dissipation Derating (Ta $\geq$ 25°C, 1 Circuit)	$\Delta P_C / ^\circ\text{C}$	-1.5(*-3.5)	-1.0	mW / °C
	Junction Temperature	$T_j$	125		°C
Operating Temperature Range		$T_{opr}$	-55~100		°C
Storage Temperature Range		$T_{stg}$	-55~125		°C
Lead Soldering Temperature (10s)		$T_{sold}$	260(10sec)		°C
Total Package Power Dissipation		$P_T$	250(*320)	150	mW
Total Package Power Dissipation Derating (Ta $\geq$ 25°C, 1 Circuit)		$\Delta P_T / ^\circ\text{C}$	-2.5(*-3.2)	-1.5	mW / °C
Isolation Voltage (AC, 1min. , R.H. $\leq$ 60%) (Note1)		$BV_S$	5000		V rms

\*IF=20mA Max

Note: Using continuously under heavy loads (e.g. the application of high temperature/current/voltage and the significant change in temperature, etc.) may cause this product to decrease in the reliability significantly even if the operating conditions (i.e. operating temperature/current/voltage, etc.) are within the absolute maximum ratings.

Please design the appropriate reliability upon reviewing the Toshiba Semiconductor Reliability Handbook ("Handling Precautions"/"Derating Concept and Methods") and individual reliability data (i.e. reliability test report and estimated failure rate, etc).

(Note1) Device considered a two terminal device : LED side pins Shorted together and DETECTOR side pins shorted together.

## Recommended Operating Conditions

CHARACTERISTIC	SYMBOL	MIN.	TYP.	MAX.	UNIT
Supply Voltage	$V_{CC}$	—	—	200	V
Forward Current	$I_F$	—	16	25	mA
Collector Current	$I_C$	—	—	120	mA
Operating Temperature	$T_{opr}$	-25	—	85	°C

Note: Recommended operating conditions are given as a design guideline to obtain expected performance of the device. Additionally, each item is an independent guideline respectively. In developing designs using this product, please confirm specified characteristics shown in this document.

## Individual Electrical Characteristics (Ta=25°C)

CHARACTERISTIC		SYMBOL	TEST CONDITION	MIN.	TYP.	MAX.	UNIT
LED	Forward Voltage	$V_F$	$I_F = 10 \text{ mA}$	1.0	1.15	1.3	V
	Reverse Current	$I_R$	$V_R = 5 \text{ V}$	—	—	10	$\mu\text{A}$
	Capacitance	$C_T$	$V = 0, f = 1\text{MHz}$	—	30	—	pF
DETECTOR	Collector-Emitter Breakdown Voltage	$V_{(BR)CEO}$	$I_C = 0.1\text{mA}$	300	—	—	V
	Emitter-Collector Breakdown Voltage	$V_{(BR)ECO}$	$I_E = 0.1\text{mA}$	0.3	—	—	V
	Collector Dark Current	$I_{CEO}$	$V_{CE} = 200\text{V}$	—	10	200	nA
			$V_{CE} = 200\text{V}, T_a = 85^\circ\text{C}$	—	—	20	$\mu\text{A}$
Capacitance Collector to Emitter	$C_{CE}$	$V=0, f=1\text{MHz}$	—	10	—	pF	

## Coupled Electrical Characteristics (Ta=25°C)

CHARACTERISTIC	SYMBOL	TEST CONDITION	MIN.	TYP.	MAX.	UNIT
Current Transfer Ratio	$I_C/I_F$	$I_F=1\text{mA}, V_{CE}=1\text{V}$	1000	4000	—	%
Saturated CTR	$I_C/I_F(\text{sat})$	$I_F=10\text{mA}, V_{CE}=1\text{V}$	500	—	—	%
Collector-Emitter Saturation Voltage	$V_{CE}(\text{sat})$	$I_C=10\text{mA}, I_F=1\text{mA}$	—	—	1.0	V
		$I_C=100\text{mA}, I_F=10\text{mA}$	0.3	—	1.2	

## Isolation Electrical Characteristics (Ta=25°C)

CHARACTERISTIC	SYMBOL	TEST CONDITION	MIN.	TYP.	MAX.	UNIT
Capacitance Input to Output	$C_S$	$V_S=0, f=1\text{MHz}$	—	0.8	—	pF
Isolation Resistance	$R_S$	$V_S=500\text{V}, \text{R.H.} \leq 60\%$	$5 \times 10^{10}$	$10^{14}$	—	$\Omega$
Isolation Voltage	BV <sub>s</sub>	AC, 1minute	5000	—	—	V <sub>rms</sub>
		AC, 1second, in oil	—	10000	—	
		DC, 1 minute, in oil	—	10000	—	V <sub>dc</sub>

## Switching Characteristics (Ta=25°C)

CHARACTERISTIC	SYMBOL	TEST CONDITION	MIN.	TYP.	MAX.	UNIT
Rise Time	$t_r$	$V_{CC}=10V$ $I_C=10mA$ $R_L=100\Omega$	—	40	—	$\mu s$
Fall Time	$t_f$		—	15	—	
Turn-on Time	$t_{on}$		—	50	—	
Turn-off Time	$t_{off}$		—	15	—	
Turn-on Time	$t_{ON}$	$R_L=180\Omega$ (Fig.1) $V_{CC}=10V, I_F=16mA$	—	5	—	
Storage Time	$t_s$		—	40	—	
Turn-off Time	$t_{OFF}$		—	80	—	

Fig.1 SWITCHING TIME TEST CIRCUIT

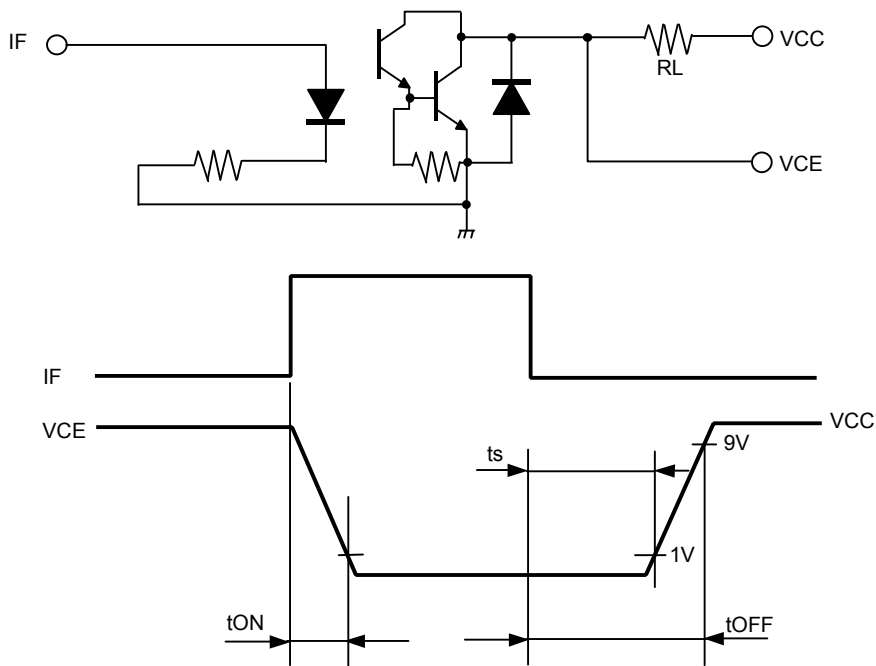

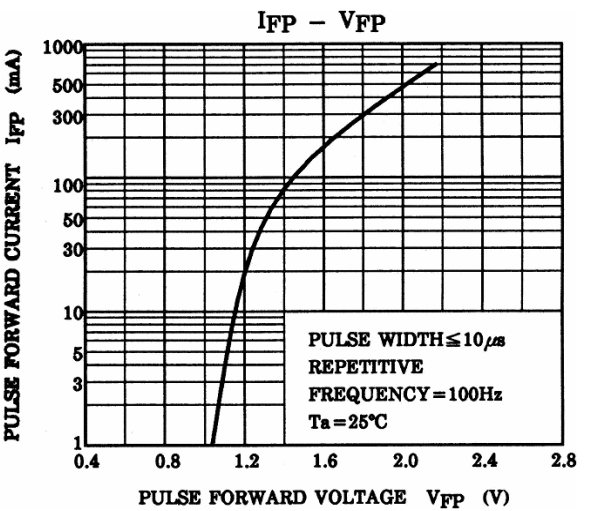
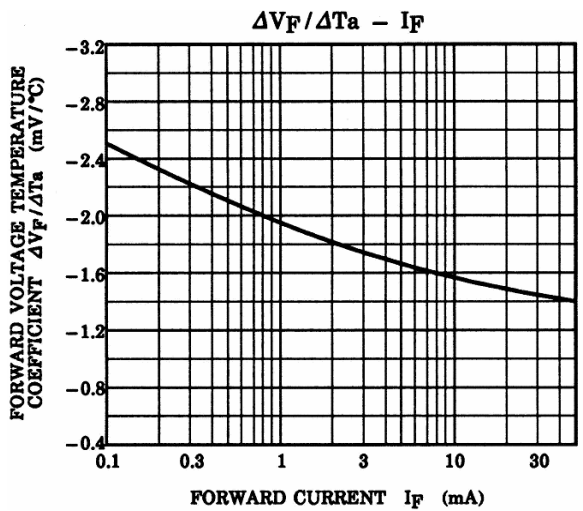
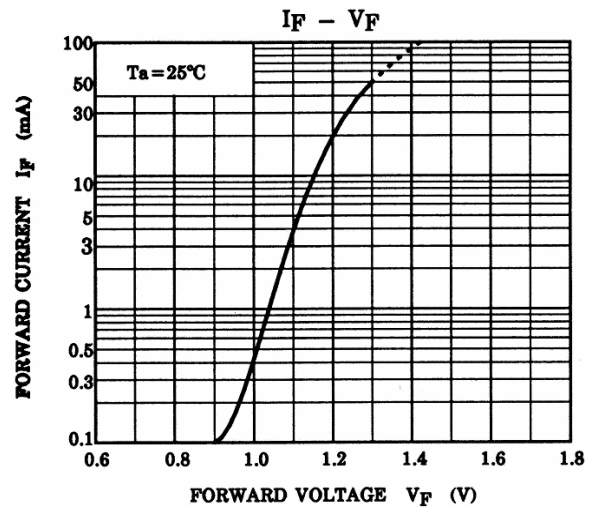
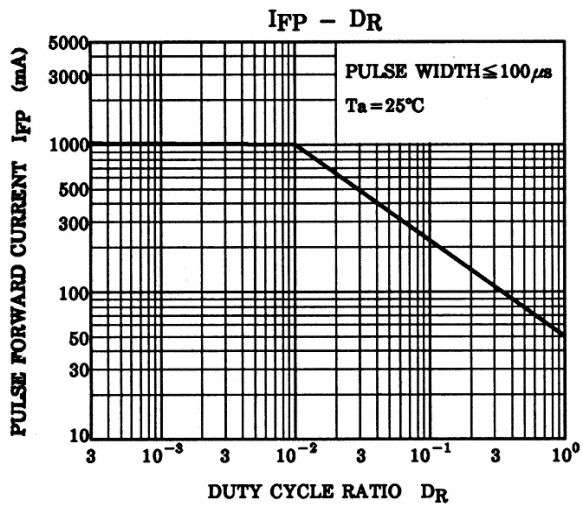
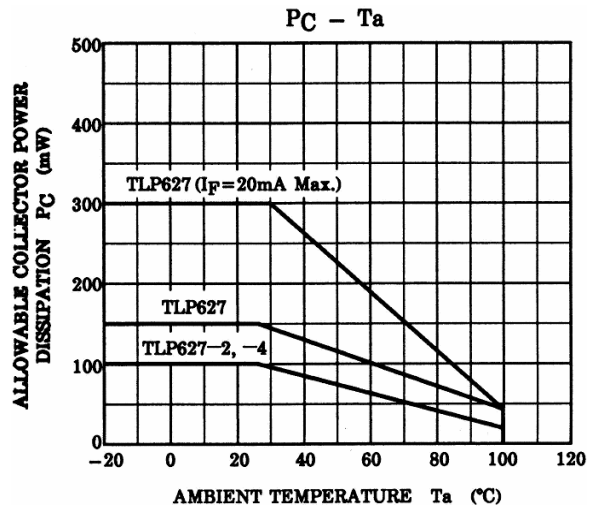
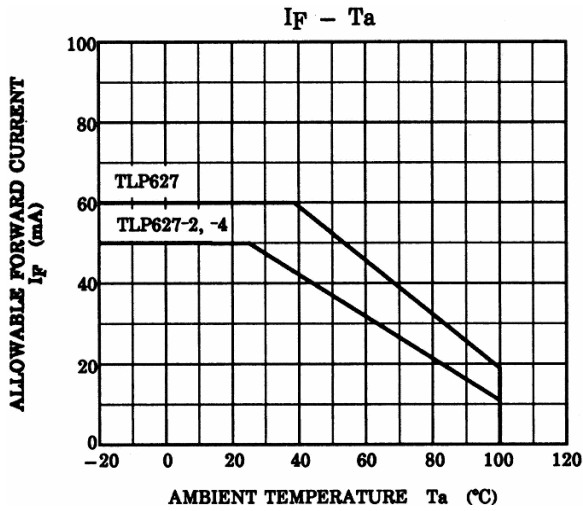

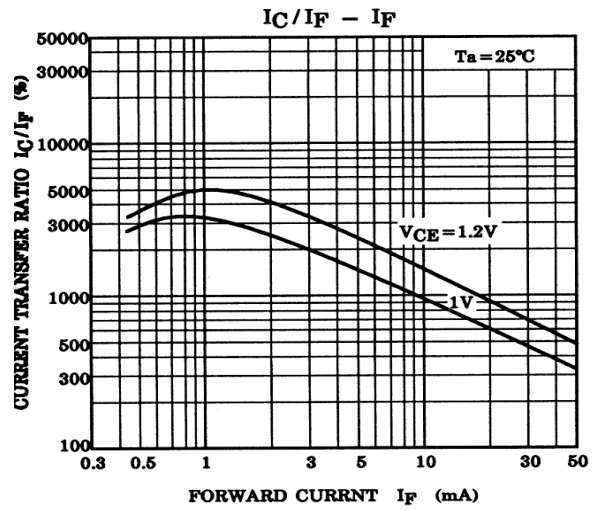
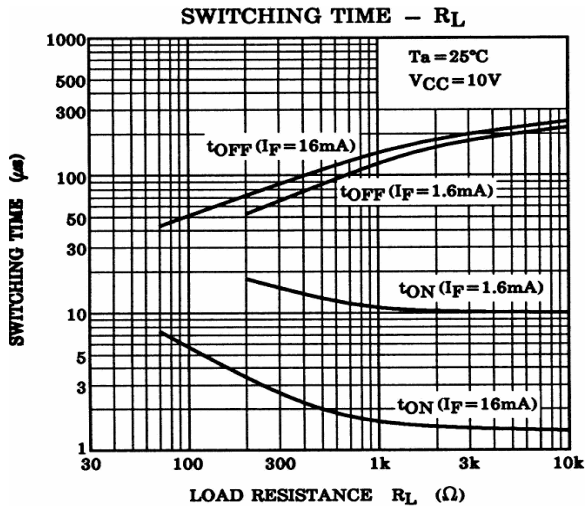
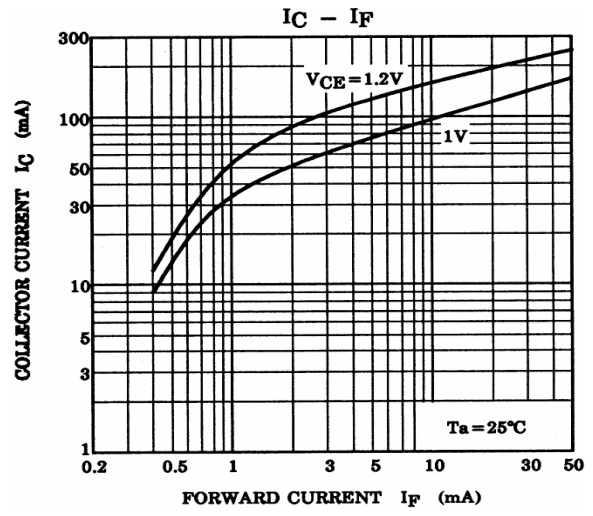
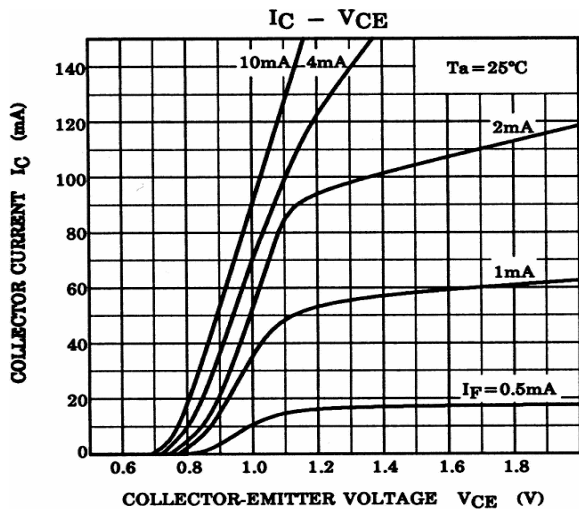

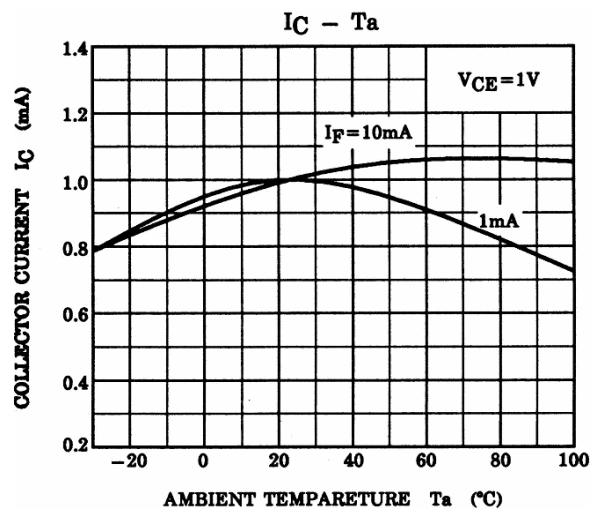
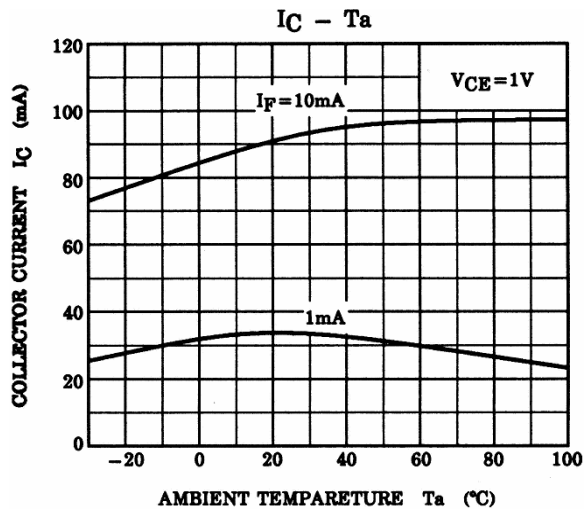
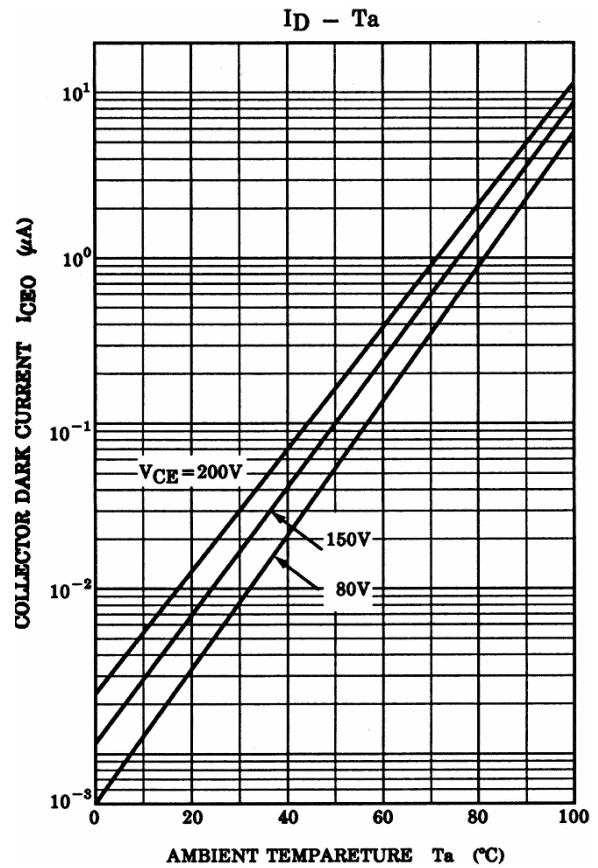
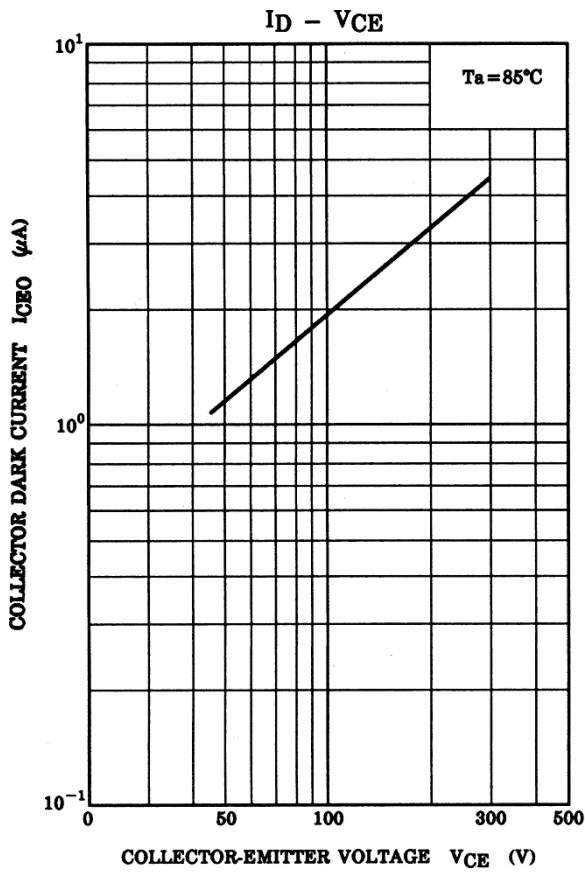

**RESTRICTIONS ON PRODUCT USE**

20070701-EN

- The information contained herein is subject to change without notice.
- TOSHIBA is continually working to improve the quality and reliability of its products. Nevertheless, semiconductor devices in general can malfunction or fail due to their inherent electrical sensitivity and vulnerability to physical stress. It is the responsibility of the buyer, when utilizing TOSHIBA products, to comply with the standards of safety in making a safe design for the entire system, and to avoid situations in which a malfunction or failure of such TOSHIBA products could cause loss of human life, bodily injury or damage to property.  
In developing your designs, please ensure that TOSHIBA products are used within specified operating ranges as set forth in the most recent TOSHIBA products specifications. Also, please keep in mind the precautions and conditions set forth in the "Handling Guide for Semiconductor Devices," or "TOSHIBA Semiconductor Reliability Handbook" etc.
- The TOSHIBA products listed in this document are intended for usage in general electronics applications (computer, personal equipment, office equipment, measuring equipment, industrial robotics, domestic appliances, etc.). These TOSHIBA products are neither intended nor warranted for usage in equipment that requires extraordinarily high quality and/or reliability or a malfunction or failure of which may cause loss of human life or bodily injury ("Unintended Usage"). Unintended Usage include atomic energy control instruments, airplane or spaceship instruments, transportation instruments, traffic signal instruments, combustion control instruments, medical instruments, all types of safety devices, etc.. Unintended Usage of TOSHIBA products listed in this document shall be made at the customer's own risk.
- The products described in this document shall not be used or embedded to any downstream products of which manufacture, use and/or sale are prohibited under any applicable laws and regulations.
- The information contained herein is presented only as a guide for the applications of our products. No responsibility is assumed by TOSHIBA for any infringements of patents or other rights of the third parties which may result from its use. No license is granted by implication or otherwise under any patents or other rights of TOSHIBA or the third parties.
- GaAs(Gallium Arsenide) is used in this product. The dust or vapor is harmful to the human body. Do not break, cut, crush or dissolve chemically.
- Please contact your sales representative for product-by-product details in this document regarding RoHS compatibility. Please use these products in this document in compliance with all applicable laws and regulations that regulate the inclusion or use of controlled substances. Toshiba assumes no liability for damage or losses occurring as a result of noncompliance with applicable laws and regulations.