

DIMENSIONS :- METRIC(INCH)

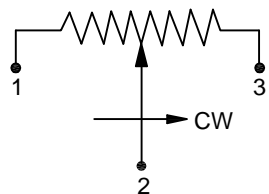

ELECTRICAL SCHEMATIC DIAGRAM

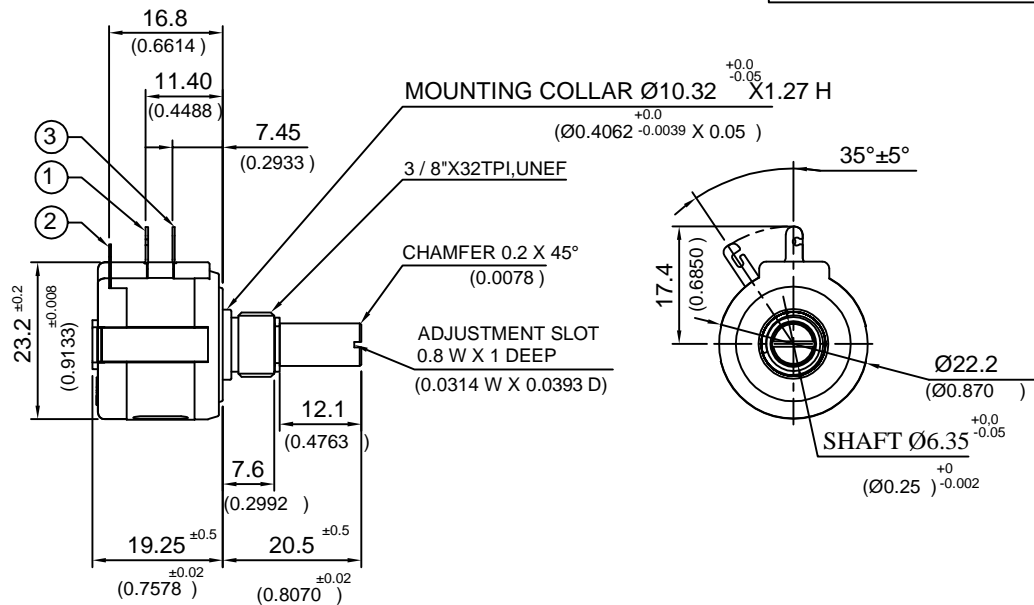

REAR SIDE VIEW

ELECTRICAL CHARACTERISTICS :-	UNITS	VALUE
RESISTANCE ELEMENT...	--	WIRE WOUND
TOTAL RESISTANCE...	Ohms	1K,2K,5K,10K
RESISTANCE TOLERANCE...	%	±10
INDEPENDENT LINEARITY TOLERANCE...(IEC 60393)..	%	±0.5
EFFECTIVE ELECTRICAL ANGLE...	DEGREES	1800° +10° - 0°
RESOLUTION...	--	AS PER TURNS
POWER RATING @ 70°C...	WATTS	2
EQUIVALENT NOISE RESISTANCES...	Ohms	100
INSULATION RESISTANCE @ 500 VDC...	M Ohms	1000
DIELECTRIC STRENGTH @ 50 HZ...	V ac	750 MINIMUM
MAXIMUM WIPER CURRENT...	mAmps	1.0
SHORT TIME WIPER CURRENT 10 SEC. ...	mAmps	10
END RESISTANCE...	%	0.1% OR 5 OHMS WHICH IS HIGHER

MECHANICAL CHARACTERISTICS :-		
ROTATION (MECHANICAL ANGLE) WITH END STOP	DEGREES	1800° +10° - 0°
BEARING TYPE...	--	SLEEVE
STOPPER STRENGTH	N.cm Oz inch	45 (31.7797)
TORQUE... STARTING...	N.cm Oz inch	0.5 (0.708)
NUT TIGHTENING TORQUE...	N.m	0.8 MAX
SPANNER SIZE OF NUT...	--	14
AXIAL PLAY...	mm	0.2
RADIAL PLAY...	mm	0.15

ENVIRONMENTAL CHARACTERISTICS :-		
OPERATING TEMPERATURE...	DEGREES C	-40 to +125°C
ROHS COMPLIANCE...	---	Yes
VIBRATION...	G	15
SHOCK	G	50

PERFORMANCE :-		
ROTATIONAL LIFE (SHAFT REVOLUTIONS)...	Nos.	1,000,000

MATERIALS OF CONSTRUCTION:-		
HOUSING...	--	PLASTIC CAPRI BLUE
SHAFT...	--	STAINLESS STEEL
TERMINALS...	--	BRASS, GOLD PLATED
MOUNTING HARDWARE	--	LOCK WASHER-STEEL + NUT-BRASS, A/F 14 X 3 MM,BOTH NICKEL PLATED

SOLDERING RECOMMENDATION :- USE SOLDERING IRON AT 350° C FOR 3 SECOND MAXIMUM.
Clean the soldered pads with Isopropyl alcohol after soldering.
Continuous improvements are being made for enhancing performance for customer benefit in product design & process. The product supplied may be slightly different than described by above specifications

UNI-AUTOMATION (I) PVT LTD Tel/Fax:+91-(020)-24420890 www.uniautomation.com		MULTI TURN WIRE WOUND POTENTIOMETER	
FIRST ISSUE : 2016/23/12		NHP22	
SCALE:- 1:1		MULTI TURN POTENTIOMETER (10TURN)	
TOLERANCES DIN-ISO 2768-1 (1991-06) (Tolerance class-medium)	UAPL PART NO 139016	CUSTOMER DRAWING REF NO NA	REV - 00
		CUSTOMER : UAPL STANDARD	SHEET 1of1