

LVDS Reduces EMI

Abstract

As the complexity and speed of electronic products increase, the amount of Electromagnetic Interference (EMI) emissions also grow dramatically. Increasing data rates and tougher Electromagnetic Compatibility (EMC) standards make electromagnetic radiation a heightened concern. This, coupled with the proliferation of portable and wireless products, increases the chance of interference between systems, making EMI emissions more of a problem. This application note discusses alternatives and features offered by Low Voltage Differential Signaling (LVDS) to reduce EMI emissions.

What Causes EMI?

EMI radiation is fundamentally caused by any charge moving in an electrical field or change in an electrical field. Typically any electrical transitions with sharp edges -- such as clock, data, address and control signals -- produce electromagnetic radiation. In digital systems, periodic clock signals are the major cause of EMI. Control and timing signals, address and data buses, interconnect cables and connectors also contribute to EMI emissions.

Two main modes of electromagnetic radiation are:

- "Differential mode", caused by local current loops between printed circuit board (PCB) interconnect traces and the ground plane(s)
- "Common mode", caused by the coupling of ground and power plane noise into traces, input/output buses, and cable lines.

Problems caused by EMI have increased with the proliferation of mobile electronic systems, wireless communication systems and computer networks. To address problems associated with EMI radiation, designers can use several approaches, which may involve:

1. Developing alternative technologies, which radiate less EMI interference.
2. Design more effective techniques with existing technologies.

LVDS Features Reduce EMI

EMI is generated by current changes in a conductor and increases with the rate and the amplitude of that change. Low Voltage Differential Signaling (LVDS) features a low swing differential constant current source configuration and due to this small signal change, relatively little EMI is radiated from the conductor. Refer to Figure 1 which illustrates relative comparisons of signal levels for some common data transmission standards.

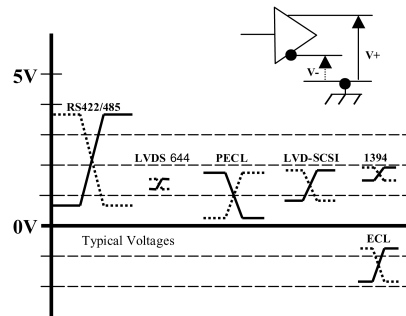

FIGURE 1. Signal Level Comparisons of Common Data Transmission Standards

Digital signals can change logic states much faster when the signal transitions do not have as far to go to change states. A reduced voltage swing with a small constant current results in lower power in the transmission medium and at the load. Reduced signal transitions that are relatively faster than other interface technologies, such as RS-422, not only reduce EMI but push up the frequency of operation spectrum. (Note: The FCC continues to raise the upper frequency limit for EMI compliance.)

Differential Signaling Cancels EMI

In single-ended signaling topologies such as CMOS/TTL, PECL and RS-232, almost all the electrical field lines are free to radiate outward from the single conductor. Other objects can intercept these fields, but some can travel as Transverse Electromagnetic Mode (TEM) waves, which may escape the system and cause EMI. With balanced differential devices signal lines, the fields around the two electrical paths oppose each other, and the concentric magnetic fields tend to react with one another and cancel each other (Figure 2). The electrical coupling of the two conductors allows cancellation of most of the low frequency fields. These coupled electric fields are "tied up" and cannot escape to propagate as TEM waves beyond the immediate vicinity of the conductors. Only the stray fringing fields are allowed to escape, resulting in much less field energy available to propagate as TEM waves.

Differential Signaling Cancels EMI (Continued)

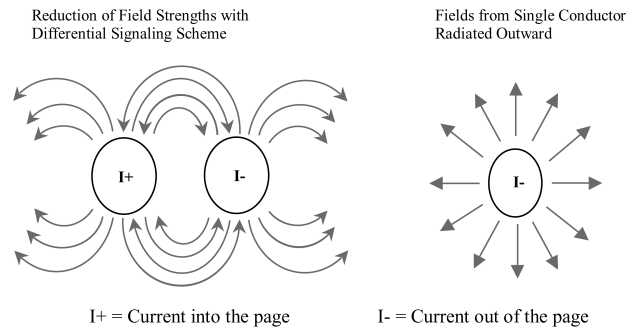

FIGURE 2. Fields interact and cancel out in differential topologies

When the differential transmission lines are closely coupled, the induced signal is common-mode noise that appears as a common-mode voltage at the receiver input. The differential receiver responds only to the difference between the plus and the minus inputs, so when the noise appears commonly to both inputs, the input differential signal amplitude is undisturbed. This common-mode noise rejection also applies to noise sources such as power supply variations, substrate noise, and ground bounce.

Controlling EMI

By examining the fundamentals of interference control, a conceptual understanding of EMI control can be gained. As shown in Figure 3, the EMI control problem consists of three elements, a source, a sensitive circuit or system and the intervening space structure or energy mechanism.

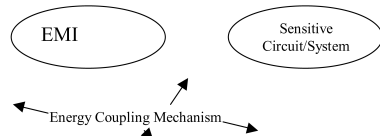

FIGURE 3. The Basic Elements of the Interference Control Problem

Controlling EMI includes reducing the source and the sensitivity of the circuit. As illustrated in Figure 4, these approaches are typically achieved by placing an electromagnetic barrier around the source of EMI, the sensitive circuit or both.

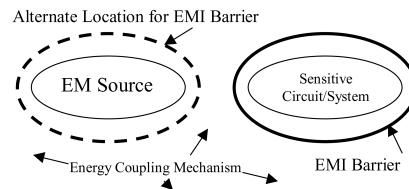

FIGURE 4. EMI Control with Barriers

When dealing with an EM source such as outputs of IC's, it would appear that very little can be done to control EMI or crosstalk. With the rise time of the output, the currents governed by the capability of the drivers, and the loads on the lines, there are several approaches that can address this -- such as series resistors on the outputs of single-ended systems.

Controlling the coupling mechanisms involves techniques such as controlling the impedance, self-inductance and self-shielding of the circuit via controlling component positions and the length and position of the conductors and planes of the PC board. The sensitive circuit or system is often beyond our control, since we have created a design with little emphasis on the first two elements discussed, and the only option is to provide EM shielding in the system. A complete EMI barrier is a closed surface that prevents both space waves and guided waves (conducted interference) from passing through it. The barrier usually consists of a metal shield, such as the equipment case, filters or other devices to limit the interference current. This solution tends to increase the costs of the systems.

Summary and Conclusions

Differential signal paths reduce the harmful effects of these fields to further minimize radiation problems. Balanced differential lines have equal but opposite currents, called odd-mode signals. When the fields created by these odd-mode signals are closely coupled, they tend to tie each other up and thus cannot escape to cause harm. Therefore, it is important to maintain a balanced and closely coupled differential transmission path to reduce the emission of electromagnetic interference. Differential signals also have the advantage of tolerating interference from outside sources such as inductive radiation from electric motors or crosstalk from neighboring transmission lines.

To solve the problem of twisted-pair cables or flex circuit carrying high-speed data through the panel hinge without creating EMI problems, system designers chose to use LVDS technology because it has better EMI performance than all other interface technologies.

Fairchild does not assume any responsibility for use of any circuitry described, no circuit patent licenses are implied and Fairchild reserves the right at any time without notice to change said circuitry and specifications.

LIFE SUPPORT POLICY

FAIRCHILD'S PRODUCTS ARE NOT AUTHORIZED FOR USE AS CRITICAL COMPONENTS IN LIFE SUPPORT DEVICES OR SYSTEMS WITHOUT THE EXPRESS WRITTEN APPROVAL OF THE PRESIDENT OF FAIRCHILD SEMICONDUCTOR CORPORATION. As used herein:

1. Life support devices or systems are devices or systems which, (a) are intended for surgical implant into the body, or (b) support or sustain life, and (c) whose failure to perform when properly used in accordance with instructions for use provided in the labeling, can be reasonably expected to result in a significant injury to the user.
2. A critical component in any component of a life support device or system whose failure to perform can be reasonably expected to cause the failure of the life support device or system, or to affect its safety or effectiveness.

www.fairchildsemi.com