

< Low Noise GaAs HEMT >

MGF4953B

Leadless ceramic package

DESCRIPTION

The MGF4953B super-low noise InGaAs HEMT (High Electron Mobility Transistor) is designed for use in K band amplifiers.

The lead-less ceramic package assures minimum parasitic losses.

FEATURES

- Low noise figure @ f=20GHz
NFmin. = 0.55dB (Typ.)
- High associated gain @ f=20GHz
Gs = 10.5dB (Typ.)

APPLICATION

C to K band low noise amplifiers

QUALITY GRADE

GG

RECOMMENDED BIAS CONDITIONS

VDS=2V, ID=10mA

ORDERING INFORMATION

Tape & reel 10,000pcs/reel (MGF4953B-01)

Tape & reel 10,000pcs/reel (MGF4953B-70)

RoHS COMPLIANT

MGF4953B is a RoHS compliant product. RoHS compliance is indicated by the letter "G" after the Lot Marking.

ABSOLUTE MAXIMUM RATINGS (Ta=25°C)

Symbol	Parameter	Ratings	Unit
VGDO	Gate to drain voltage	-3	V
VGSO	Gate to source voltage	-3	V
ID	Drain current	60	mA
PT	Total power dissipation	50	mW
Tch	Channel temperature	125	°C
Tstg	Storage temperature	-55 to +125	°C

ELECTRICAL CHARACTERISTICS (Ta=25°C)

Symbol	Parameter	Test conditions	Limits			Unit
			MIN.	TYP.	MAX	
V(BR)GDO	Gate to drain breakdown voltage	IG=-10μA	-3	--	--	V
Igss	Gate to source leakage current	VGS=-2V, VDS=0V	--	--	50	μA
IDSS	Saturated drain current	VGS=0V, VDS=2V	15	--	60	mA
VGS(off)	Gate to source cut-off voltage	VDS=2V, ID=500μA	-0.1	--	-1.5	V
Gs	Associated gain	VDS=2V, ID=10mA, f=20GHz	9.0	10.5	--	dB
NFmin.	Minimum noise figure		--	0.55	0.80	dB

Note: Gs and NFmin. are tested with sampling inspection.

Outline Drawing

Fig.1

MITSUBISHI Proprietary

Not to be reproduced or disclosed without permission by Mitsubishi Electric

Fig.1

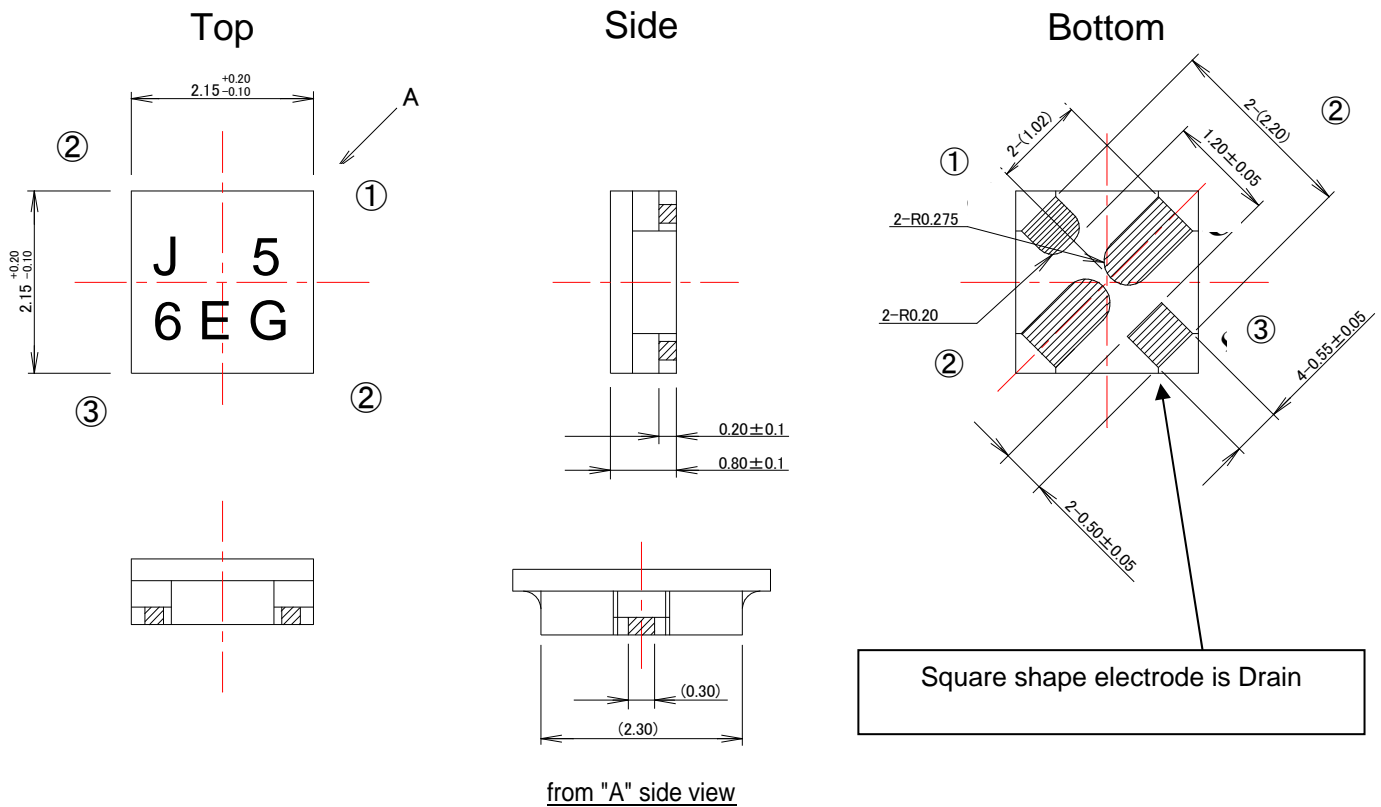

Unit: mm

- ① Gate
- ② Source
- ③ Drain

TYPICAL CHARACTERISTICS (Ta=25°C)

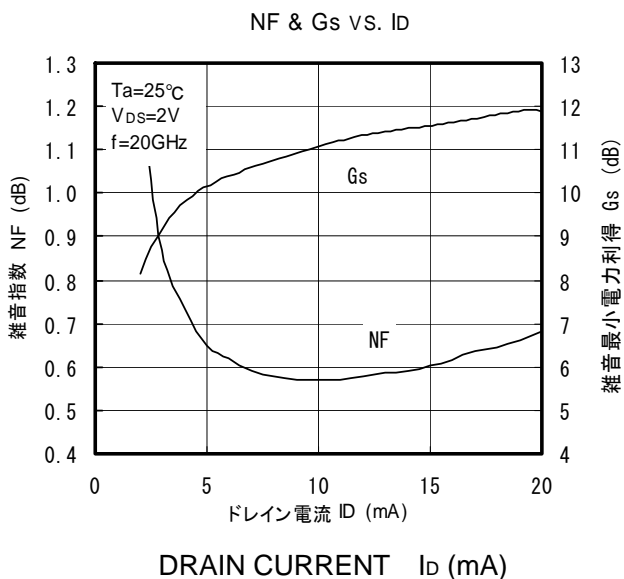
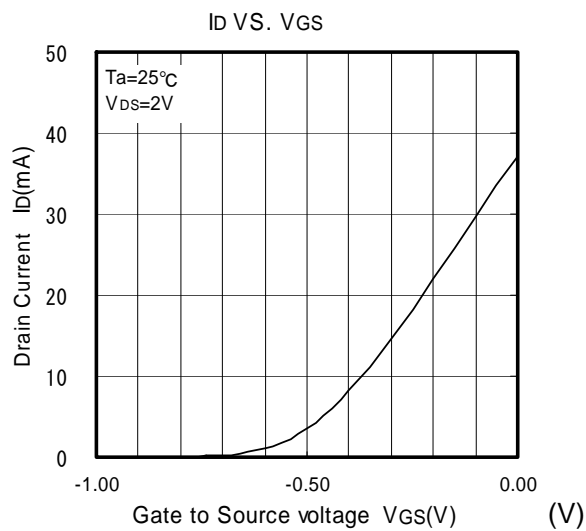
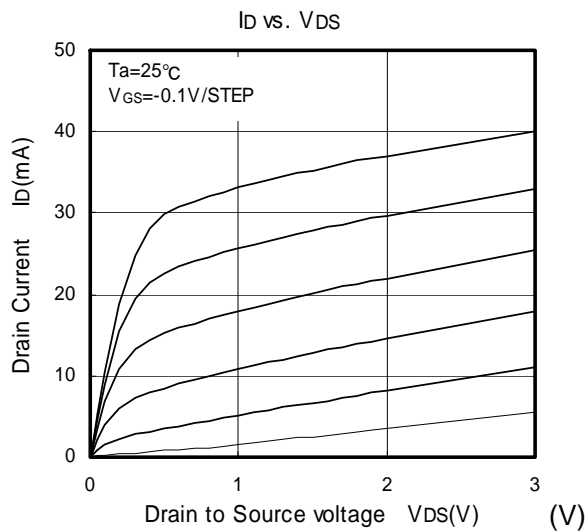

S PARAMETERS

(VDS=2V, ID=10mA, Ta=25°C)

Freq. (GHz)	S11		S21		S12		S22	
	(mag)	(ang)	(mag)	(ang)	(mag)	(ang)	(mag)	(ang)
1	0.989	-4.0	5.212	166.6	0.038	82.4	0.689	-10.7
2	0.968	-20.4	5.101	152.0	0.046	72.4	0.669	-21.1
3	0.942	-36.8	4.989	137.3	0.054	62.4	0.640	-31.5
4	0.927	-53.2	4.877	122.7	0.062	52.4	0.604	-41.9
5	0.857	-69.5	4.766	108.0	0.070	42.4	0.554	-52.4
6	0.787	-85.8	4.655	93.4	0.078	32.4	0.505	-62.7
7	0.716	-101.5	4.524	79.3	0.085	23.5	0.454	-72.7
8	0.654	-119.2	4.378	64.9	0.093	13.5	0.399	-84.1
9	0.582	-135.3	4.162	52.0	0.095	4.9	0.341	-93.6
10	0.525	-152.8	4.008	39.5	0.095	-2.5	0.288	-102.8
11	0.494	-170.2	3.887	27.3	0.096	-8.4	0.250	-113.0
12	0.474	171.2	3.761	15.2	0.096	-14.2	0.212	-124.7
13	0.471	152.0	3.656	2.9	0.097	-20.6	0.180	-140.4
14	0.484	134.6	3.593	-9.4	0.096	-26.0	0.159	-156.4
15	0.501	118.4	3.522	-21.9	0.095	-33.2	0.155	-175.5
16	0.544	101.2	3.335	-36.1	0.098	-37.5	0.163	153.3
17	0.579	86.8	3.209	-49.3	0.099	-42.9	0.182	132.4
18	0.612	73.6	3.038	-62.7	0.101	-49.3	0.216	110.1
19	0.646	62.0	2.814	-73.7	0.102	-56.2	0.260	90.7
20	0.688	50.3	2.726	-85.1	0.107	-63.9	0.301	76.3
21	0.733	39.4	2.613	-96.7	0.112	-75.1	0.340	59.0
22	0.765	28.6	2.499	-108.3	0.115	-86.3	0.370	48.0
23	0.798	17.7	2.384	-120.0	0.119	-97.5	0.405	37.0
24	0.831	6.9	2.269	-131.6	0.123	-108.7	0.444	30.2
25	0.831	-3.9	2.152	-143.2	0.127	-119.9	0.483	23.1
26	0.814	-14.7	2.034	-154.8	0.131	-131.1	0.522	17.1

NOISE PARAMETERS (VDS=2V, ID=10mA, Ta=25°C)

Freq. (GHz)	NFmin (dB)	Γ_{opt}		Rn (Ω)
		(mag)	(ang)	
12	0.38	0.44	140.9	2.5
13	0.40	0.40	160.3	1.5
14	0.43	0.38	-179.4	2.0
15	0.45	0.36	-158.4	2.0
16	0.48	0.36	-136.6	3.0
17	0.50	0.36	-114.2	4.0
18	0.53	0.38	-91.2	6.0
19	0.57	0.39	-67.9	8.5
20	0.63	0.41	-44.5	11.5
21	0.72	0.45	-21.1	15.0
22	0.80	0.48	2.1	19.0
23	0.92	0.54	25.2	24.0
24	1.00	0.57	48.1	29.5
25	1.14	0.61	70.9	37.5
26	1.24	0.63	93.6	50.0

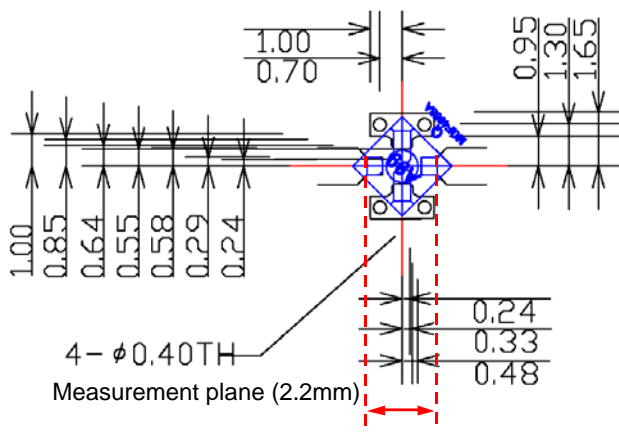

Board; RO4003C (Rogers Corp.)
 $\epsilon_r=3.38$, $t=0.508\text{mm}$, Au (Cu) = 0.035mm

Note:

We are ready to provide nonlinear model for ADS and MWO users. If you are interested, please contact our sales offices.

S PARAMETERS

(VDS=2V, ID=10mA, Ta=25°C)

Freq. (GHz)	S11		S21		S12		S22	
	(mag)	(ang)	(mag)	(ang)	(mag)	(ang)	(mag)	(ang)
1	0.989	-13.0	4.537	165.8	0.014	78.9	0.637	-9.7
2	0.973	-25.9	4.502	152.9	0.028	71.8	0.629	-19.6
3	0.949	-38.7	4.472	140.4	0.041	62.7	0.621	-29.2
4	0.926	-52.0	4.460	127.3	0.054	53.2	0.608	-39.0
5	0.890	-64.9	4.431	114.9	0.066	44.4	0.592	-48.2
6	0.828	-81.1	4.394	99.8	0.076	33.4	0.539	-60.1
7	0.776	-95.6	4.311	86.3	0.085	24.1	0.505	-70.2
8	0.723	-110.6	4.230	73.2	0.093	15.2	0.469	-80.4
9	0.662	-126.6	4.094	59.9	0.099	5.4	0.423	-90.7
10	0.605	-142.6	3.943	47.4	0.102	-4.0	0.368	-100.2
11	0.551	-158.2	3.826	35.4	0.102	-12.9	0.318	-108.8
12	0.514	-174.5	3.740	23.7	0.100	-19.7	0.279	-116.3
13	0.488	167.0	3.622	11.2	0.099	-28.1	0.232	-126.2
14	0.486	149.0	3.572	-1.1	0.098	-32.1	0.203	-138.3
15	0.480	131.8	3.512	-12.6	0.094	-38.4	0.169	-148.1
16	0.509	113.0	3.425	-26.2	0.099	-43.0	0.148	-175.1
17	0.536	95.1	3.349	-39.1	0.099	-49.9	0.133	157.1
18	0.569	78.2	3.226	-52.1	0.100	-58.5	0.132	120.7
19	0.609	62.7	3.091	-66.1	0.099	-66.5	0.160	92.2
20	0.642	47.3	2.934	-79.2	0.096	-75.2	0.204	67.8
21	0.674	34.3	2.752	-91.8	0.091	-83.8	0.250	50.6
22	0.707	21.1	2.617	-104.8	0.089	-92.5	0.293	37.0
23	0.742	9.2	2.471	-117.4	0.082	-102.8	0.350	23.8
24	0.753	-2.2	2.307	-130.2	0.081	-111.9	0.390	13.5
25	0.775	-12.5	2.139	-142.4	0.072	-118.9	0.430	2.4
26	0.803	-22.5	2.008	-155.0	0.069	-135.9	0.474	-5.7

NOISE PARAMETERS (VDS=2V, ID=10mA, Ta=25°C)

Freq. (GHz)	Γ_{opt}		Rn	NFmin (dB)
	(mag)	(ang)		
18	0.358	-137.2	0.12	0.51
20	0.372	-91.0	0.14	0.55
22	0.390	-47.7	0.63	0.77
24	0.417	-14.9	1.05	1.05
26	0.473	10.5	1.26	1.25

Note) Rn is normalized by 50ohm

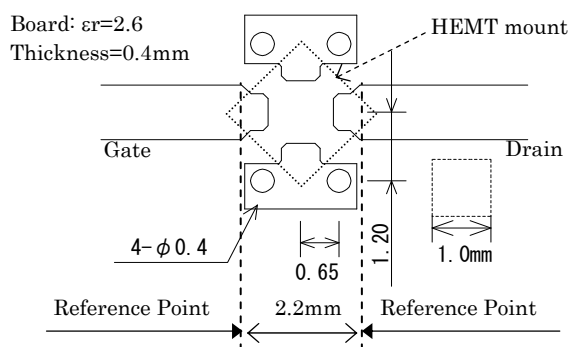

Note:

We are ready to provide nonlinear model for ADS and MWO users. If you are interested, please contact our sales offices.

Keep safety first in your circuit designs!

- Mitsubishi Electric Corporation puts the maximum effort into making semiconductor products better and more reliable, but there is always the possibility that trouble may occur with them. Trouble with semiconductors may lead to personal injury, fire or property damage. Remember to give due consideration to safety when making your circuit designs, with appropriate measures such as (i) placement of substitutive, auxiliary circuits, (ii) use of non-flammable material or (iii) prevention against any malfunction or mishap.

Notes regarding these materials

- These materials are intended as a reference to assist our customers in the selection of the Mitsubishi semiconductor product best suited to the customer's application; they do not convey any license under any intellectual property rights, or any other rights, belonging to Mitsubishi Electric Corporation or a third party.
- Mitsubishi Electric Corporation assumes no responsibility for any damage, or infringement of any third-party's rights, originating in the use of any product data, diagrams, charts, programs, algorithms, or circuit application examples contained in these materials.
- All information contained in these materials, including product data, diagrams, charts, programs and algorithms represents information on products at the time of publication of these materials, and are subject to change by Mitsubishi Electric Corporation without notice due to product improvements or other reasons. It is therefore recommended that customers contact Mitsubishi Electric Corporation or an authorized Mitsubishi Semiconductor product distributor for the latest product information before purchasing a product listed herein.
The information described here may contain technical inaccuracies or typographical errors.
Mitsubishi Electric Corporation assumes no responsibility for any damage, liability, or other loss rising from these inaccuracies or errors.
Please also pay attention to information published by Mitsubishi Electric Corporation by various means, including the Mitsubishi Semiconductor home page (<http://www.mitsubishielectric.com/>).
- When using any or all of the information contained in these materials, including product data, diagrams, charts, programs, and algorithms, please be sure to evaluate all information as a total system before making a final decision on the applicability of the information and products. Mitsubishi Electric Corporation assumes no responsibility for any damage, liability or other loss resulting from the information contained herein.
- Mitsubishi Electric Corporation semiconductors are not designed or manufactured for use in a device or system that is used under circumstances in which human life is potentially at stake. Please contact Mitsubishi Electric Corporation or an authorized Mitsubishi Semiconductor product distributor when considering the use of a product contained herein for any specific purposes, such as apparatus or systems for transportation, vehicular, medical, aerospace, nuclear, or undersea repeater use.
- The prior written approval of Mitsubishi Electric Corporation is necessary to reprint or reproduce in whole or in part these materials.
- If these products or technologies are subject to the Japanese export control restrictions, they must be exported under a license from the Japanese government and cannot be imported into a country other than the approved destination.
Any diversion or re-export contrary to the export control laws and regulations of Japan and/or the country of destination is prohibited.
- Please contact Mitsubishi Electric Corporation or an authorized Mitsubishi Semiconductor product distributor for further details on these materials or the products contained therein.