

Powerex Darlington Transistor Modules are in wide use in inverter and power supply circuits. The last development in this bipolar technology was the High Beta family of products which were designed to simplify the base circuit design for users and has been well accepted in the Market particularly at the

400 and 500 Ampere area. As it is the mission of Powerex to continually provide our customers with the leading edge technology we are recommending that new designs consider our 3rd generation H-Series IGBT's or 3rd generation Intelligent Power modules as these new technologies will provide the

lowest total Power loss and additional design benefits. Complete detailed specifications and application notes on the Darlington Transistors may be found in [Powerex Semiconductor Data Book](#), Volume 1 or contact the factory or your local Powerex manufacturers' representative.

Darlington Transistor Selector Table*

Type $I_C(A)$ / $V_{CE0}(V)$	Non-Isolated	Fast Single F or A			Single S			Chopper R	
	300	200	1000	600	1000	1200	600	1000	
15				KS8245A1 (D1)					
30/40*			KSA21K03 (D17)	KS524503 (D2)	KS221K03 (D3)		KR224503 (D18)	KR221K03 (D19)	
50		KSF22005 (D4)		KS524505 (D2)	KS221K05 (D3)		KR224505 (D18)	KR221K05 (D19)	
75/80*				KS524575 (D2)			KR224575 (D18)	KR221K75 (D21)	
100	KSC23010 (D13)			KS224510 (D5)	KS221K10 (D3)		KR324510 (D20)	KR421K10 (D23)	
150				KS224515 (D5)	KS221K15 (D6)		KR324515 (D20)	KR421K15 (D23)	
200	KSB23020 (D14)			KS324520 (D7)	KS621K20 (D8)	KS621220A7 (D8)			
300	KSB23030 (D15)			KS624530 (D9)	KS621K30 (D8)	KS621230A7 (D8)			
400					KS621K40 (D11)	KS621240 (D11)			
600	KSB13060 (D16)				KS621K60 (D12)	KS621260 (D12)			

Darlington Transistor Selector Table* Continued

Type $I_C(A)$ / $V_{CE0}(V)$	Common Emitter C	Dual D				Six-in-1		
	600	600	1000	1200	1400	600	1000	1200
10						KEE24501 (D41) KED24501 (D42)		
15		KD7245A1 (D24)	KD721KA1 (D25)	KD7212A1 (D25)		KED245A1 (D42)	KE721KA1 (D43)	KE7212A1 (D43)
20		KD724502 (D24)				KED24502 (D42)		
30/40*	KC224503 (D22)	KD224503 (D27)	KD221K03 (D26)	KD221203 (D26)	KD221404* (D28)		KE721K03 (D44)	KE721203 (D44)
50	KC224505 (D22)	KD224505 (D27)	KD221K05 (D26)	KD221205A7 (D26)		KE524505 (D46)	KE921K05 (D45)	KE921205 (D45)
75/80*	KC224575 (D22)	KT524575 (D37) KD224575 (D27)	KD221K75 (D29)	KD221275A7 (D29)	KD321408* (D30)	KE524575 (D46)		
100	KC324510 (D40)	KT224510 (D38) KD324510 (D31)	KD421K10 (D32)	KD421210 (D32)		KE524510 (D46)		
150	KC324515 (D40)	KT224515 (D38) KD324515 (D31)	KD421K15 (D32)	KD421215 (D32)	KD421415 (D33)			
200		KD424520 (D34)	KD621K20 (D35)	KD621220 (D35)				
300			KD621K30 (D36)	KD621230 (D36)				



Powerex, Inc., 200 Hillis Street, Youngwood, Pennsylvania 15697-1800 (412) 925-7272
 Powerex, Europe, S.A. 428 Avenue G. Durand, BP107, 72003 Le Mans, France (43) 41.14.14

High Beta Darlington Transistor Selector Table*

Type I _C (A) / V _{CEO} (V)	Single S		Dual D			Six-in-1		
	600	1200	600	1000	1200	600	1000	1200
10						KEE24501HB (D57)		
15						KED245A1HB (D58)		KE7212A1HB (D59)
20						KED24502HB (D60)	KE721KA1HB (D59)	KE721203HB (D63)
30			KD224503HB (D48)			KEF24503HB (D61) KE524503HB (D62)	KE721K03HB (D63)	
50			KD224505HB (D48)	KD221K05HB (D49)	KD221205HB (D49)	KET24505HB (D64) KE524505HB (D62)	KE921205HB (D65)	
75			KD224575HB (D50)	KD221K75HB (D51)	KD221275HB (D51)	KET24575HB (D66) KE524575HB (D62)		
100			KD324510HB (D52)	KD421K10HB (D53)	KD421210HB (D53)	KET24510HB (D67) KE524510HB (D62)		
150			KD324515HB (D52)	KD421K15HB (D53)	KD421215HB (D53)			
200			KD424520HB (D54)	KD621K20HB (D55)	KD621220HB (D55)			
300				KD621K30HB (D56)	KD621230HB (D56)			
400	KS624540 (D10)							
500	KS624550 (D10)							
600								
1000		KS62121KHB (D47)						

*Powerex recommends the use of H-Series IGBT or 3rd generation Intelligent Power Modules for new designs.

Powerex, Inc., 200 Hillis Street, Youngwood, Pennsylvania 15697-1800 (412) 925-7272
 Powerex, Europe, S.A. 428 Avenue G. Durand, BP107, 72003 Le Mans, France (43) 41.14.14

D1

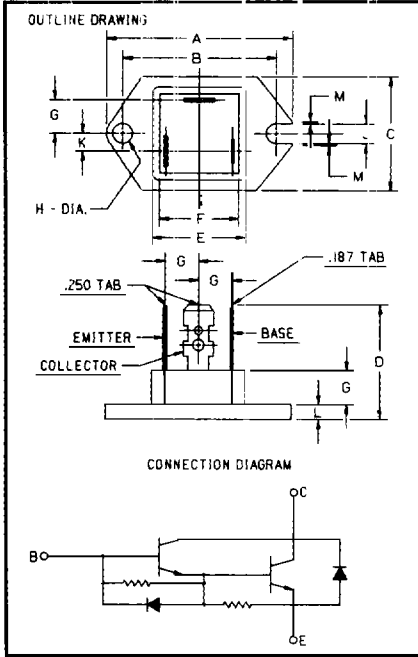

Dimension	Inches	Millimeters
A	1.535 Max.	39.0 Max.
B	1.268 ± 0.008	32.2 ± 0.2
C	0.945 Max.	24.0 Max.
D	0.945	24.0
E	0.768 Max.	19.5 Max.
F	0.656	16.6
G	0.276	7.0
H	0.165 ± 0.004 Dia.	4.2 ± 0.1 Dia.
J	0.165	4.2
K	0.146	3.7
L	0.126	3.2
M	0.016	0.4

KS8245A1

D2

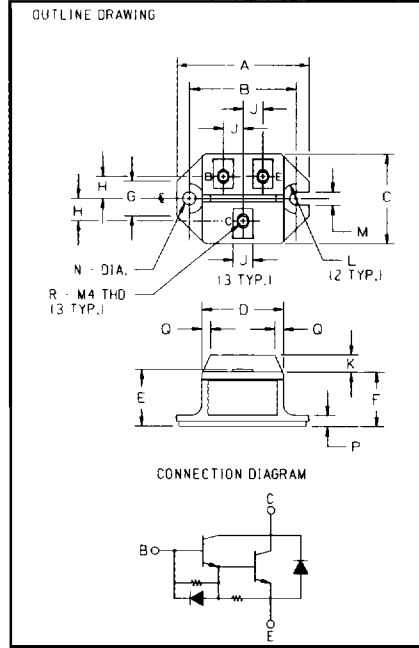

Dimension	Inches	Millimeters
A	2.106	53.5
B	1.705 ± 0.008	43.3 ± 0.2
C	1.437	36.5
D	1.299	33.0
E	0.925	23.5
F	0.866	22.0
G	0.551	14.0
H	0.354	9.0
J	0.315	8.0
K	0.276	7.0
L	0.236 Rad.	6.0 Rad.
M	0.209	5.3
N	0.209 Dia.	5.3 Dia.
P	0.177	4.5
Q	0.138	3.5
R	M4 Metric	M4

KS524503, KS524505, KS524575

D3

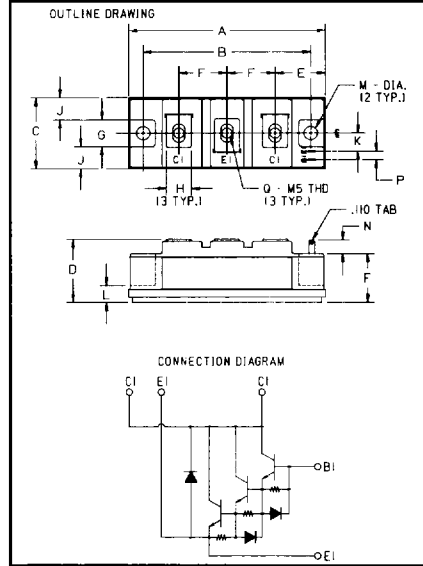

Dimension	Inches	Millimeters
A	3.701 Max.	94 Max.
B	3.150 ± 0.01	80.0 ± 0.25
C	1.339 Max.	34.0 Max.
D	1.181 Max.	30.0 Max.
E	0.945	24.0
F	0.906	23.0
G	0.512	13.0
H	0.472	12.0
J	0.413	10.5
K	0.344	8.75
L	0.315	8.0
M	0.256 Dia.	6.5 Dia.
N	0.256 Min.	6.5 Min.
P	0.157	4.0
Q	M5 Metric	M5

KS221K03, KS221K05, KS221K10

D4

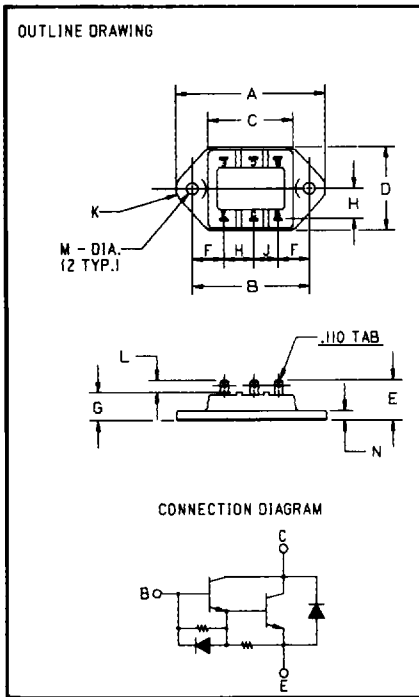

Dimension	Inches	Millimeters
A	2.185 Max.	55.5 Max.
B	1.705 ± 0.012	43.3 ± 0.3
C	1.240	31.5
D	1.220 Max.	31.0 Max.
E	0.59 ± 0.02	16.0 ± 0.5
F	0.459	11.65
G	0.453	11.5
H	0.433 ± 0.012	11 ± 0.3
J	0.354 ± 0.012	9 ± 0.3
K	0.236 Rad.	6.0 Rad.
L	0.177	4.5
M	0.169 Dia.	4.3 Dia.
N	0.138	3.5

KSF22005

D5

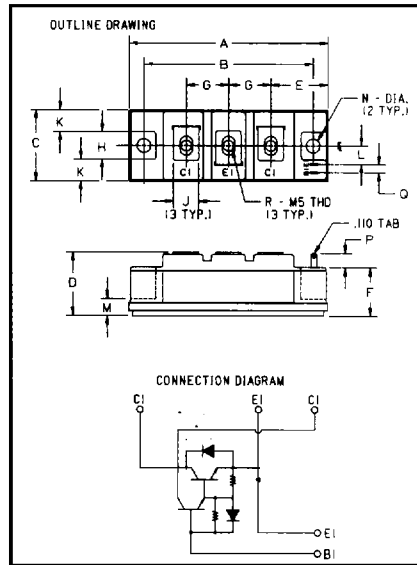

Dimension	Inches	Millimeters
A	3.701 Max.	94.0 Max.
B	3.150 ± 0.010	80.0 ± 0.25
C	1.339 Max.	34.0 Max.
D	1.181 Max.	30.0 Max.
E	1.063	27.0
F	0.906	23.0
G	0.787	20.0
H	0.512	13.0
J	0.472	12.0
K	0.413	10.5
L	0.344	8.75
M	0.315	8.0
N	0.256 Dia.	6.5 Dia.
P	0.256 Min.	6.5 Min.
Q	0.157	4.0
R	M5 Metric	M5

KS224510, KS224515

D6

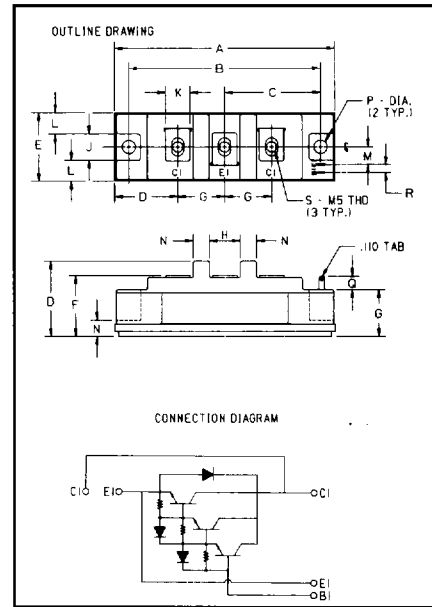

Dimension	Inches	Millimeters
A	4.252 Max.	108.0 Max.
B	3.661 ± 0.012	93.0 ± 0.3
C	1.831	46.5
D	1.457	37.0
E	1.339 Max.	34.0 Max.
F	1.181 Max.	30.0 Max.
G	0.906	23.0
H	0.591	15.0
J	0.512	13.0
K	0.472	12.0
L	0.413	10.5
M	0.344	8.75
N	0.315	8.0
P	0.256 Dia.	6.5 Dia.
Q	0.256 Min.	6.5 Min.
R	0.157	4.0
X	M5 Metric	M5

KS221K15

D7

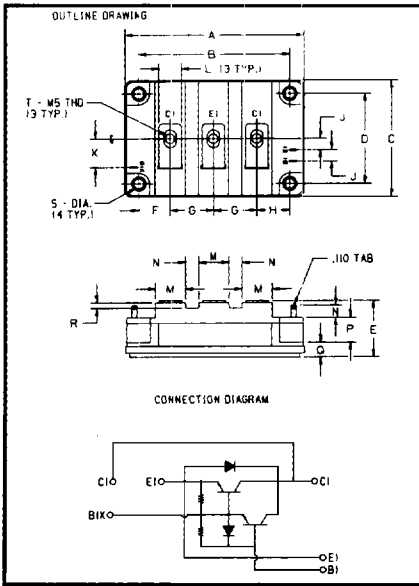

Dimension	Inches	Millimeters
A	3.740 Max.	95.0 Max.
B	3.150 ± 0.01	80.0 ± 0.25
C	2.441 Max.	62.0 Max.
D	1.89 ± 0.1	48.0 ± 0.25
E	1.181 Max.	30.0 Max.
F	0.650	16.5
G	0.906	23.0
H	0.689	17.5
J	0.236	6.0
K	0.596	15.0
L	0.472	12.0
M	0.630	16.0
N	0.276	7.0
P	0.512	13.0
Q	0.315	8.0
R	0.118	3.0
S	0.216 Dia.	5.5 Dia.
T	M5 Metric	M5

KS324520, KS325520

D8

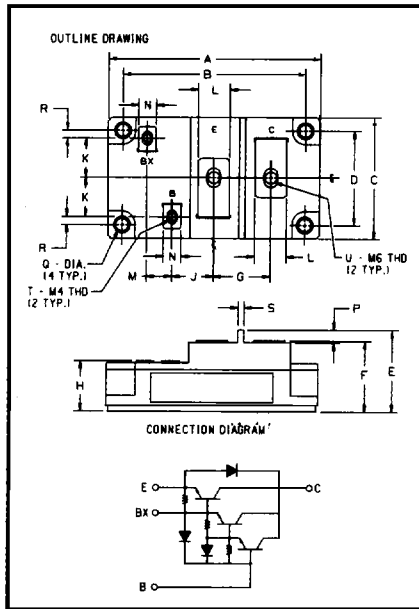

Dimension	Inches	Millimeters
A	4.252 Max.	108.0 Max.
B	3.661 ± 0.012	93.0 ± 0.3
C	2.441 Max.	62.0 Max.
D	1.89 ± 0.012	48.0 ± 0.3
E	1.634 Max.	41.5 Max.
F	1.417 Max.	36.0 Max.
G	1.142	29.0
H	1.004	25.5 Max.
J	0.827	21.0
K	0.787	20.0
L	0.630	16.0
M	0.512	13.0
N	0.354	9.0
P	0.256	6.5
Q	0.256 Dia.	6.5 Dia.
R	0.157	4.0
S	0.118	3.0
T	M4 Metric	M4
U	M6 Metric	M6

KS621K20, KS621220A7, KS621K30,
 KS621230A7, KS621K40A41

D9

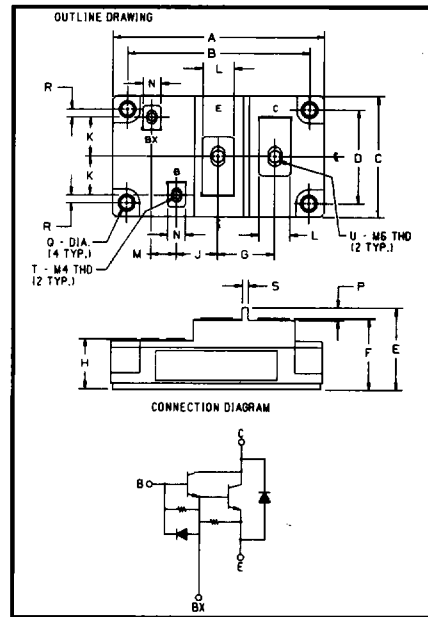

Dimension	Inches	Millimeters
A	4.252 Max.	108.0 Max.
B	3.661 ± 0.012	93.0 ± 0.3
C	2.441 Max.	62.0 Max.
D	1.89 ± 0.012	48.0 ± 0.3
E	1.634 Max.	41.5 Max.
F	1.417 Max.	36.0 Max.
G	1.142	29.0
H	1.004	25.5
J	0.827	21.0
K	0.787	20.0
L	0.630	16.0
M	0.512	13.0
N	0.354	9.0
P	0.256	6.5
Q	0.256 Dia.	6.5 Dia.
R	0.157	4.0
S	0.118	3.0
T	M4 Metric	M4
U	M6 Metric	M6

KS624530

D10

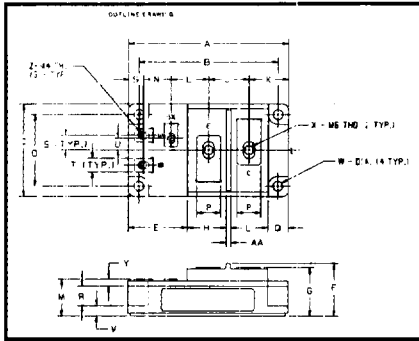

Dimension	Inches	Millimeters
A	4.212	107.0
B	3.661	93.0
C	2.441	62.0
D	1.890 ± 0.1	48.0 ± 0.25
E	1.476	37.5
F	1.378 Max.	35.0 Max.
G	1.268	32.2
H	1.102	28.0
J	1.063	27.0
K	1.043	26.5
L	0.984	25.0
M	0.964	24.5
N	0.728	18.5
P	0.630	16.0
Q	0.531	13.5
R	0.512	13.0
S	0.394	10.0
T	0.354	9.0
U	0.315	8.0
V	0.276	7.0
W	0.256 Dia.	6.5 Dia.
X	M6 Metric	M6
Y	0.177	4.5
Z	M4 Metric	M4
AA	0.118	3.0

KS624540, KS624550

D11

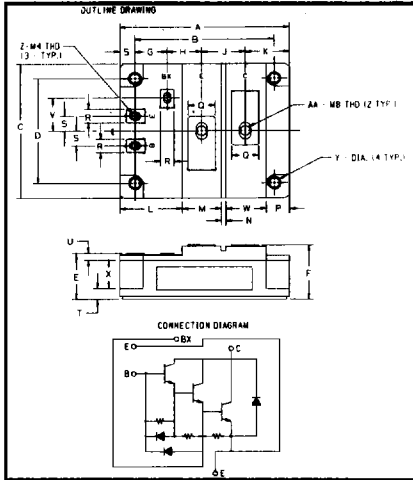

Dimension	Inches	Millimeters
A	4.449 Max.	113.0 Max.
B	3.661 ± 0.012	93.0 ± 0.3
C	3.543 Max.	90.0 Max.
D	2.756 ± 0.012	70.0 ± 0.3
E	1.181 Max.	30.0 Max.
F	1.417 Max.	36.0 Max.
G	0.846	21.5
H	0.906	23.0
J	1.142	29.0
K	1.161	29.5
L	1.634	41.5
M	1.024	26.0
N	0.118	3.0
P	0.610	15.5
Q	0.709	18.0
R	0.354	9.0
S	0.394	10.0
T	0.276	7.0
U	0.177	4.5
V	0.866	22.0
W	1.063	27.0
X	0.728	18.5
Y	0.256 Dia.	6.5 Dia.
Z	M4 Metric	M4
AA	M8 Metric	M8

KS621K40, KS621240

D12

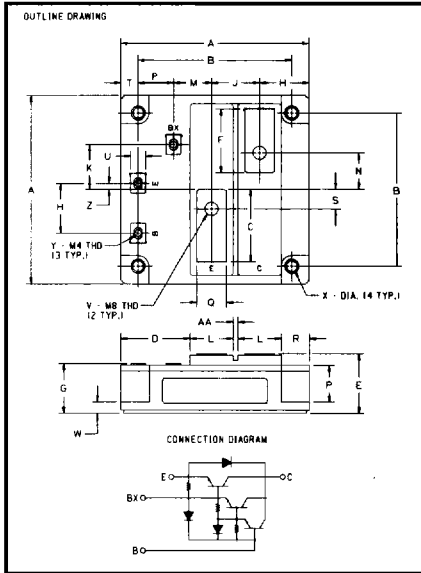

Dimension	Inches	Millimeters
A	4.488	114.0
B	3.661 ± 0.012	93.0 ± 0.3
C	1.654	42.0
D	1.417 Max.	36.0 Max.
E	1.181 Max.	30.0 Max.
F	1.181	30.0
G	1.142	29.0
H	1.063	27.0
J	1.024	26.0
K	0.906	23.0
L	0.866	22.0
M	0.846	21.5
N	0.709	18.0
P	0.669	17.0
Q	0.472	12.0
R	0.413	10.5
S	0.354	9.0
T	M8 Metric	M8
U	0.276	7.0
V	0.256 Dia.	6.5 Dia.
W	M4 Metric	M4
X	0.118	3.0

KS621K60, KS621260

D13

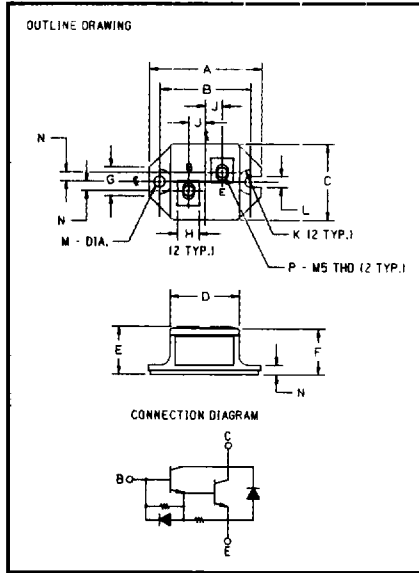

Dimension	Inches	Millimeters
A	2.106	53.5
B	1.705 ± 0.008	43.3 ± 0.2
C	1.437	36.5
D	1.299	33.0
E	0.925	23.5
F	0.866	22.0
G	0.551	14.0
H	0.413	10.5
J	0.315	8.0
K	0.236 Rad.	6.0 Rad.
L	0.209	5.3
M	0.209 Dia.	5.3 Dia.
N	0.177	4.5
P	M5 Metric	M5

KSC23010

D14

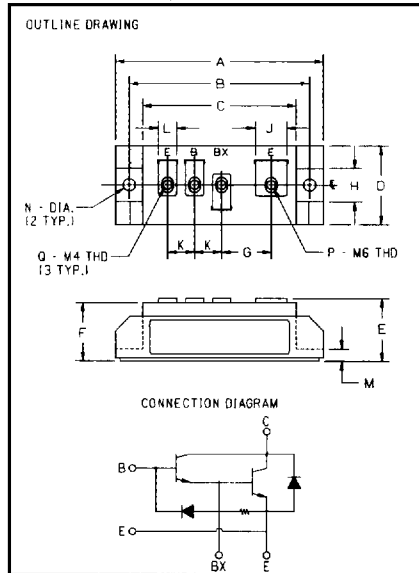

Dimension	Inches	Millimeters
A	3.630	92.2
B	3.150	80.0
C	2.677	68.0
D	1.378	35.0
E	1.102	28.0
F	1.024	26.0
G	0.866	22.0
H	0.591	15.0
J	0.551	14.0
K	0.216	12.0
L	0.315	8.0
M	0.177	4.5
N	0.216 Dia.	5.5 Dia.
P	M6 Metric	M6
Q	M4 Metric	M4

KSB23020

D15

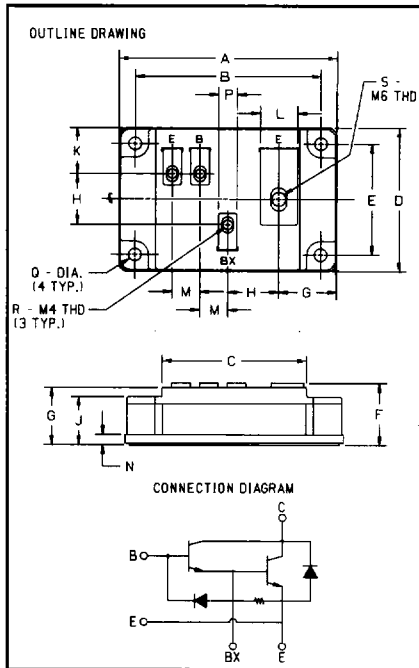

Dimension	Inches	Millimeters
A	3.071	94.0
B	3.150 ± 0.01	80.0 ± 0.25
C	2.52	64.0
D	2.441	62.0
E	1.89 ± 0.01	48.0 ± 0.25
F	1.063 Max.	27.0 Max.
G	0.984	25.0
H	0.866	22.0
J	0.827	21.0
K	0.787	20.0
L	0.630	16.0
M	0.472	12.0
N	0.177	4.5
P	0.315	8.0
Q	0.216 Dia.	5.5 Dia.
R	M4 Metric	M4
S	M6 Metric	M6

KSB23030

D16

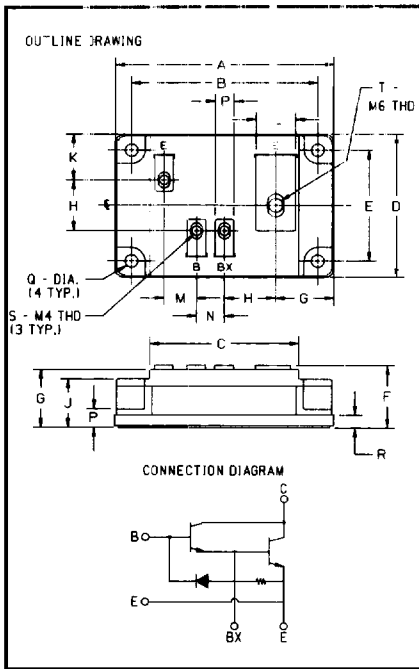

Dimension	Inches	Millimeters
A	3.701	94.0
B	3.150 ± 0.01	80.0 ± 0.25
C	2.52	64.0
D	2.441	62.0
E	1.890 ± 0.01	48.0 ± 0.25
F	1.063 Max.	27.0 Max.
G	0.984	25.0
H	0.866	22.0
J	0.827	21.0
K	0.787	20.0
L	0.669	17.0
M	0.551	14.0
N	0.472	12.0
P	0.315	8.0
Q	0.216 Dia.	5.5 Dia.
R	0.216	5.5
S	M4 Metric	M4
T	M6 Metric	M6

KSB13060

D17

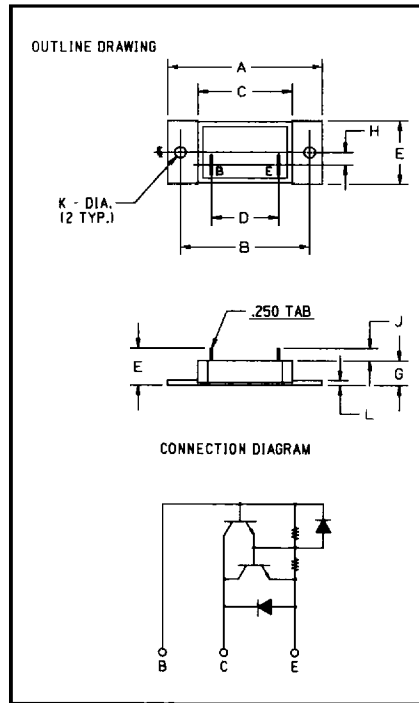

Dimension	Inches	Millimeters
A	2.441	62.0
B	2.047	52.0
C	1.496	38.0
D	1.063	27.0
E	1.024	26.0
F	0.591 Max.	15.0 Max.
G	0.394	10.0
H	0.205	5.2
J	0.197	5.0
K	0.177 Dia.	4.5 Dia.
L	0.079	2.0

KSA21K03, KSA24505

D18

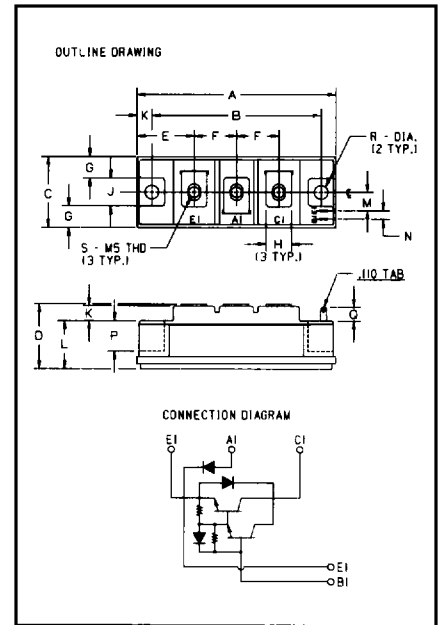

Dimension	Inches	Millimeters
A	3.701 Max.	94.0 Max.
B	3.150 ± 0.01	80.0 ± 0.25
C	1.339 Max.	34.0 Max.
D	1.220 Max.	31.0 Max.
E	1.063	27.0
F	0.787	20.0
G	0.413	10.5
H	0.472	12.0
J	0.512	13.0
K	0.276	7.0
L	0.906	23.0
M	0.344	8.75
N	0.157	4.0
P	0.571	14.5
Q	0.256 Min.	6.5 Min.
R	0.256 Dia.	6.5 Dia.
S	M5 Metric	M5

KR224503, KR224505, KR224575

D19

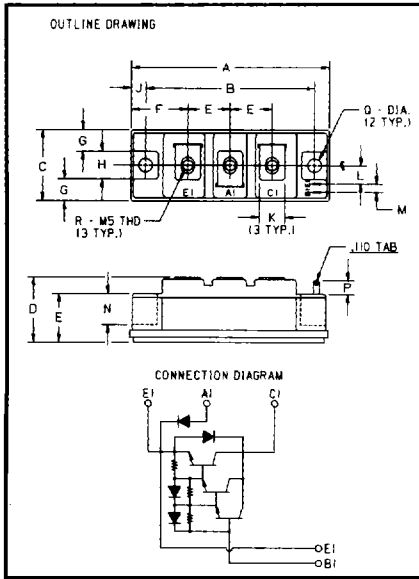

D20

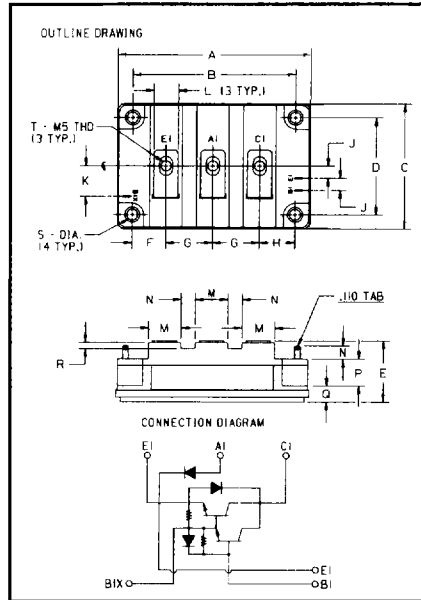

D21

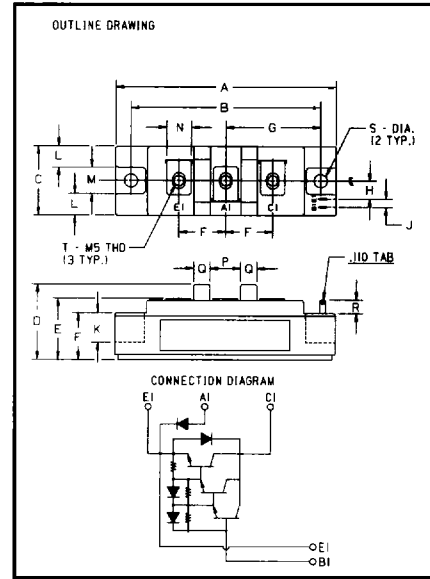

Dimension	Inches	Millimeters
A	3.701 Max.	94.0 Max.
B	3.15 ± 0.01	80.0 ± 0.25
C	1.339 Max.	34.0 Max.
D	1.181 Max.	30.0 Max.
E	0.906	23.0
F	0.945	24.0
G	0.413	10.5
H	0.512	13.0
J	0.276	7.0
K	0.472	12.0
L	0.344	8.75
M	0.157	4.0
N	0.571	14.5
P	0.256 Min.	6.5 Min.
Q	0.256 Dia.	6.5 Dia.
R	M5 Metric	M5

KR221K03, KR221K05

Dimension	Inches	Millimeters
A	3.740 Max.	95.0 Max.
B	3.150 ± 0.01	80.0 ± 0.25
C	2.441 Max.	62.0 Max.
D	1.890 ± 0.01	48.0 ± 0.25
E	1.181 Max.	30.0 Max.
F	0.650	16.5
G	0.906	23.0
H	0.689	17.5
J	0.236	6.0
K	0.596	15.0
L	0.472	12.0
M	0.630	16.0
N	0.276	7.0
P	0.512	13.0
Q	0.315	8.0
R	0.118	3.0
S	0.216 Dia.	5.5 Dia.
T	M5 Metric	M5

KR324510, KR324515

Dimension	Inches	Millimeters
A	4.252 Max.	108.0 Max.
B	3.661 ± 0.012	93.0 ± 0.3
C	1.339 Max.	34.0 Max.
D	3.425	87.0
E	1.181 Max.	30.0 Max.
F	0.906	23.0
G	1.831	46.5
H	0.344	8.75
J	0.157	4.0
K	0.571	14.5
L	0.413	10.5
M	0.512	13.0
N	0.472	12.0
P	0.591	15.0
Q	0.315	8.0
R	0.256 Min.	6.5 Min.
S	0.256 Dia.	6.5 Dia.
T	M5 Metric	M5

KR221K75

D22

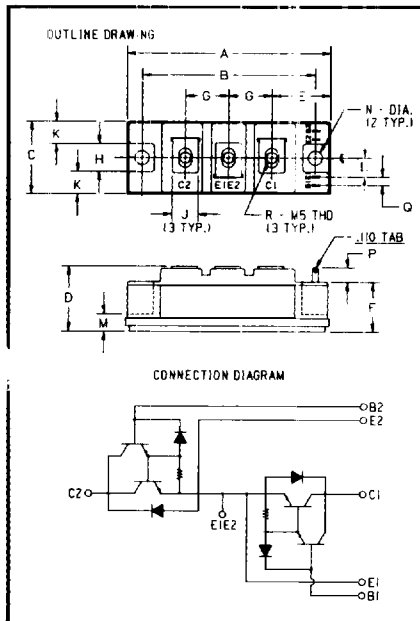

Dimension	Inches	Millimeters
A	3.701 Max.	94.0
B	3.150 ± 0.01	80.0 ± 0.25
C	1.339 Max.	34.0 Max.
D	1.181 Max.	30.0 Max.
E	1.063	27.0
F	0.906	23.0
G	0.787	20.0
H	0.512	13.0
J	0.472	12.0
K	0.413	10.5
L	0.344	8.75
M	0.315	8.0
N	0.256 Dia.	6.5 Dia.
P	0.256 Min.	6.5 Min.
Q	0.157	4.0
R	M5 Metric	M5

KC224503, KC224505,
 KC224575

D23

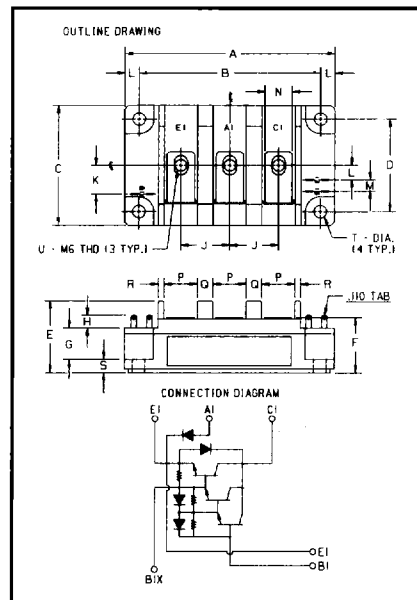

Dimension	Inches	Millimeters
A	4.252 Max.	108.0 Max.
B	3.661 ± 0.012	93.0 ± 0.3
C	2.441 Max.	62.0 Max.
D	1.890 ± 0.012	48.0 ± 0.3
E	1.457	37.0
F	1.181 Max.	30.0 Max.
G	0.630	16.0
H	0.256 Min.	6.5 Min.
J	0.984	25.0
K	0.591	15.0
L	0.295	7.5
M	0.236	6.0
N	0.551	14.0
P	0.669	17.0
Q	0.315	8.0
R	0.118	3.0
S	0.276	7.0
T	0.256 Dia.	6.5 Dia.
U	M6 Metric	M6

KR421K10, KR421K15

D24

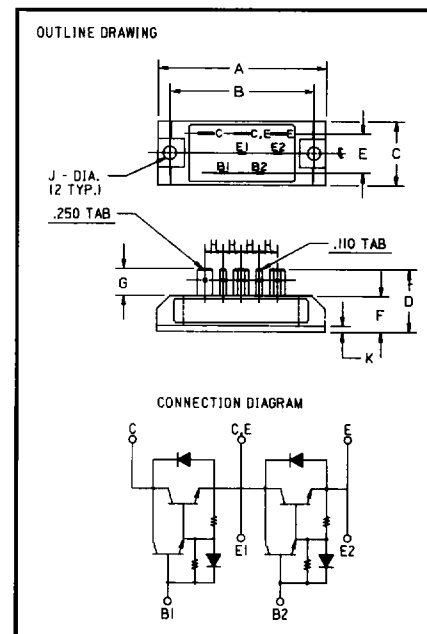

Dimension	Inches	Millimeters
A	2.756 Max.	70.0 Max.
B	2.362 ± 0.012	60.0 ± 0.3
C	1.063	27.0
D	1.024	26.0
E	0.65	16.5
F	0.591	15.0
G	0.433	11.0
H	0.315	8.0
J	0.216 Dia.	5.5 Dia.
K	0.098	2.5

KD7245A1, KD724502

D25

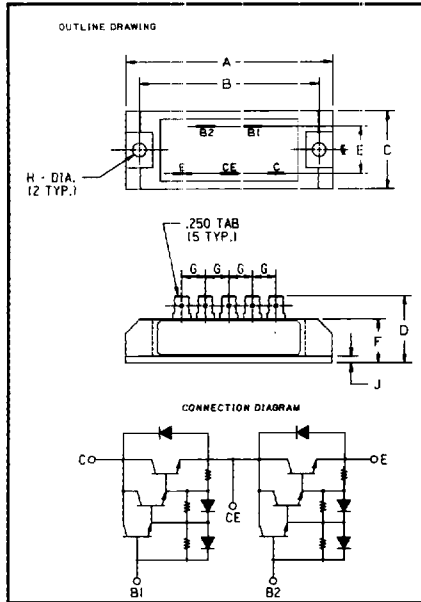

Dimension	Inches	Millimeters
A	3.622	92.0
B	3.150 ± 0.012	80.0 ± 0.3
C	1.378	35.0
D	1.181 Max.	30.0 Max.
E	0.827	21.0
F	0.768	19.5
G	0.413	10.5
H	0.216 Dia.	5.5 Dia.
J	0.177	4.5

KD721KA1, KD7212A1

D26

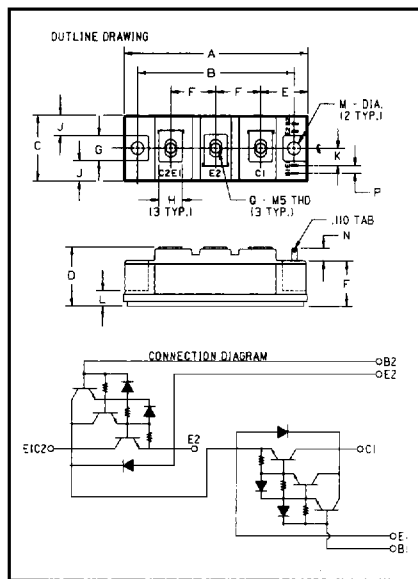

Dimension	Inches	Millimeters
A	3.701 Max.	94.0 Max.
B	3.150 ± 0.01	80.0 ± 0.25
C	1.339	34.0 Max.
D	1.181 Max.	30.0 Max.
E	0.945	24.0
F	0.906	23.0
G	0.512	13.0
H	0.472	12.0
J	0.413	10.5
K	0.344	8.75
L	0.315	8.0
M	0.256 Dia.	6.5 Dia.
N	0.256 Min.	6.5 Min.
P	0.157	4.0
Q	M5 Metric	M5

**KD221K03, KD221203,
 KD221K05, KD221205A7**

D27

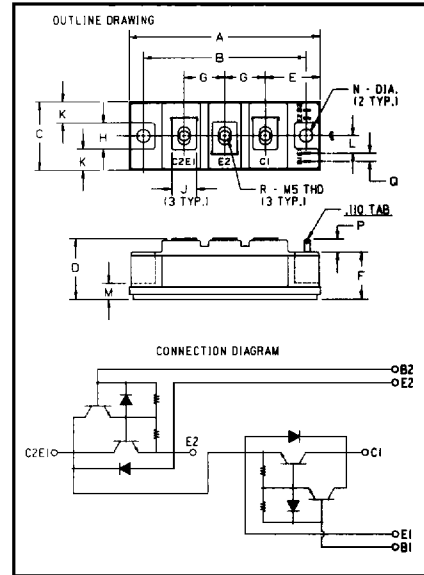

Dimension	Inches	Millimeters
A	3.701 Max.	94.0 Max.
B	3.150 ± 0.01	80.0 ± 0.25
C	1.339	34.0 Max.
D	1.181 Max.	30.0 Max.
E	1.063	27.0
F	0.906	23.0
G	0.787	20.0
H	0.512	13.0
J	0.472	12.0
K	0.413	10.5
L	0.344	8.75
M	0.315	8.0
N	0.256 Dia.	6.5 Dia.
P	0.256 Min.	6.5 Min.
Q	0.157	4.0
R	M5 Metric	M5

**KD224505, KD224575, KD224503,
 KD225575**

D28

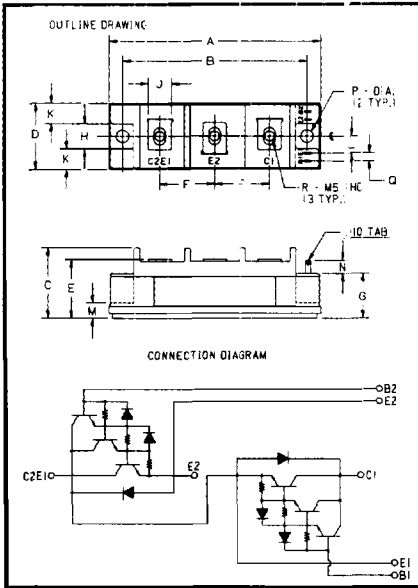

Dimension	Inches	Millimeters
A	4.252 Max.	108.0 Max.
B	3.661 ± 0.012	93.0 ± 0.3
C	1.417	36.0
D	1.339 Max.	34.0 Max.
E	1.181 Max.	30.0 Max.
F	1.102	28.0
G	0.906	23.0
H	0.512	13.0
J	0.472	12.0
K	0.413	10.5
L	0.344	8.75
M	0.315	8.0
N	0.276	7.0
P	0.256 Dia.	6.5 Dia.
Q	0.157	4.0
R	M5 Metric	M5

KD221404

D29

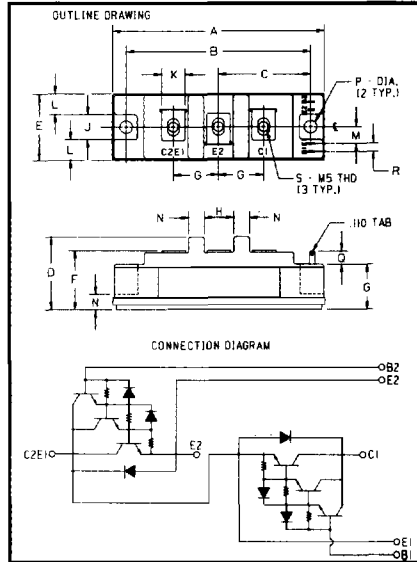

Dimension	Inches	Millimeters
A	4.252 Max.	108.0 Max.
B	3.661 ± 0.012	93.0 ± 0.3
C	1.831	46.5
D	1.457	37.0
E	1.339 Max.	34.0 Max.
F	1.181 Max.	30.0 Max.
G	0.906	23.0
H	0.591	15.0
J	0.512	13.0
K	0.472	12.0
L	0.413	10.5
M	0.344	8.75
N	0.315	8.0
P	0.256 Dia.	6.5 Dia.
Q	0.256 Min.	6.5 Min.
R	0.157	4.0
S	M5 Metric	M5

KD221K75, KD221275A7

D30

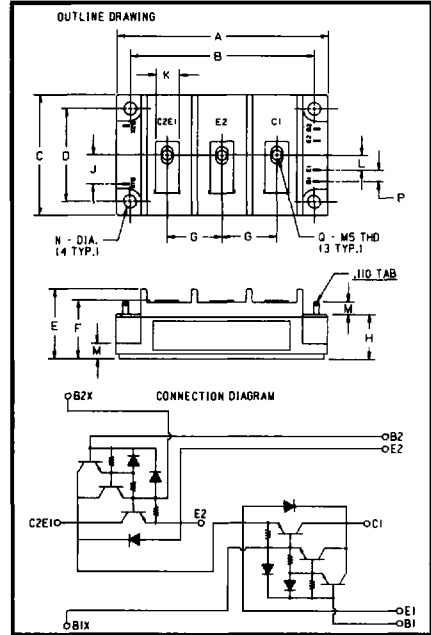

Dimension	Inches	Millimeters
A	4.252 Max.	108.0 Max.
B	3.661 ± 0.012	93.0 ± 0.3
C	2.441 Max.	62.0 Max.
D	1.89 ± 0.012	48.0 ± 0.3
E	1.147	36.0
F	1.181 Max.	30.0 Max.
G	1.102	28.0
H	0.906	23.0
J	0.591	15.0
K	0.472	12.0
L	0.295	7.5
M	0.276	7.0
N	0.256 Dia.	6.5 Dia.
P	0.236	6.0
Q	M5 Metric	M5

KD321408

D31

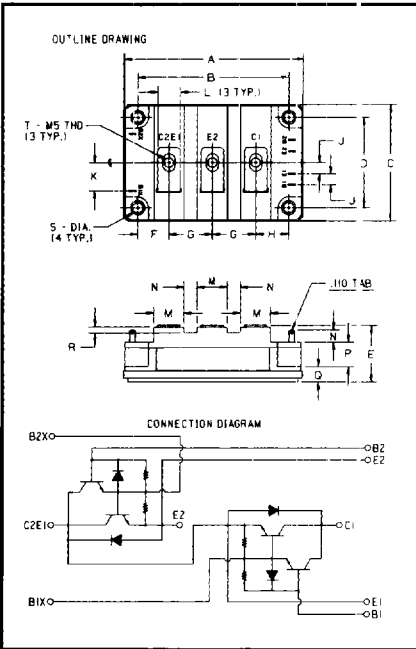

Dimension	Inches	Millimeters
A	3.740 Max.	95.0 Max.
B	3.150 ± 0.01	80.0 ± 0.25
C	2.441 Max.	62.0 Max.
D	1.890 ± 0.01	48.0 ± 0.25
E	1.181 Max.	30.0 Max.
F	0.650	16.5
G	0.906	23.0
H	0.689	17.5
J	0.236	6.0
K	0.596	15.0
L	0.472	12.0
M	0.630	16.0
N	0.276	7.0
P	0.512	13.0
Q	0.315	8.0
R	0.118	3.0
S	0.216 Dia.	5.5 Dia.
T	M5 Metric	M5

KD324510, KD324515

D32

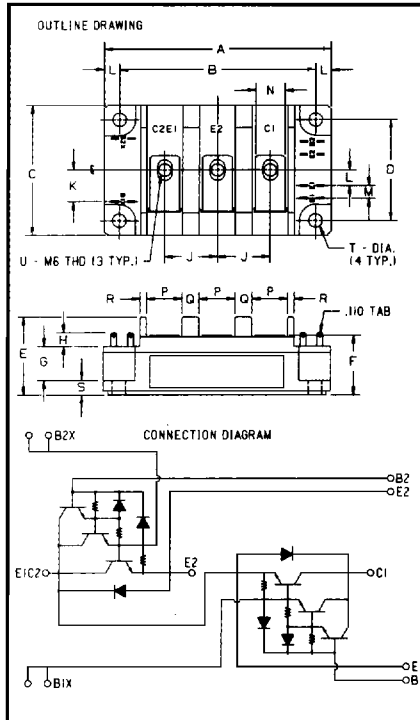

Dimension	Inches	Millimeters
A	4.252 Max.	108.0 Max.
B	3.661 ± 0.012	93.0 ± 0.3
C	2.441 Max.	62.0 Max.
D	1.890 ± 0.012	48.0 ± 0.3
E	1.457	37.0
F	1.181 Max.	30.0 Max.
G	0.630	16.0
H	0.256 Min.	6.5 Min.
J	0.984	25.0
K	0.591	15.0
L	0.295	7.5
M	0.236	6.0
N	0.551	14.0
P	0.669	17.0
Q	0.315	8.0
R	0.118	3.0
S	0.276	7.0
T	0.256 Dia.	6.5 Dia.
U	M6 Metric	M6

KD421K10, KD421210,
 KD421K15, KD421215

D33

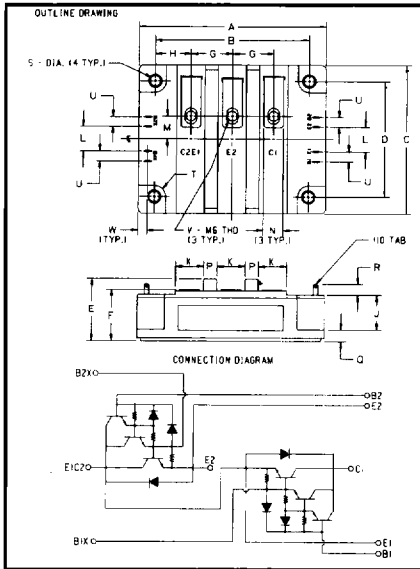

Dimension	Inches	Millimeters
A	4.45 ± 0.02	113.0 ± 0.5
B	3.661 ± 0.01	93.0 ± 0.25
C	3.54 ± 0.02	90.0 ± 0.5
D	2.756 ± 0.02	70.0 ± 0.25
E	1.48	37.5
F	1.22 Max.	31.0 Max.
G	0.98	25.0
H	0.85	21.5
J	0.83	21.0
K	0.67	17.0
L	0.59	15.0
M	0.55	14.0
N	0.47	12.0
P	0.31	8.0
Q	0.28	7.0
R	0.26 Min.	6.5 Min.
S	0.256 Dia.	6.5 Dia.
T	0.26 Rad.	6.5 Rad.
U	0.24	6.0
V	M6 Metric	M6
W	0.22	5.5

KD421415

D34

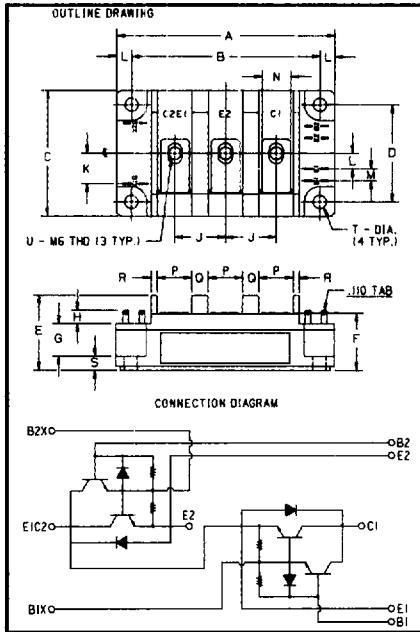

Dimension	Inches	Millimeters
A	4.252 Max.	108.0 Max.
B	3.661 ± 0.012	93.0 ± 0.3
C	2.441 Max.	62.0 Max.
D	1.89 ± 0.012	48.0 ± 0.3
E	1.457	37.0
F	1.181 Max.	30.0 Max.
G	0.63	16.0
H	0.256 Min.	6.5 Min.
J	0.984	25.0
K	0.591	15.0
L	0.295	7.5
M	0.236	6.0
N	0.551	14.0
P	0.669	17.0
Q	0.315	8.0
R	0.118	3.0
S	0.276	7.0
T	0.256 Dia.	6.5 Dia.
U	M6 Metric	M6

KD424520

D35

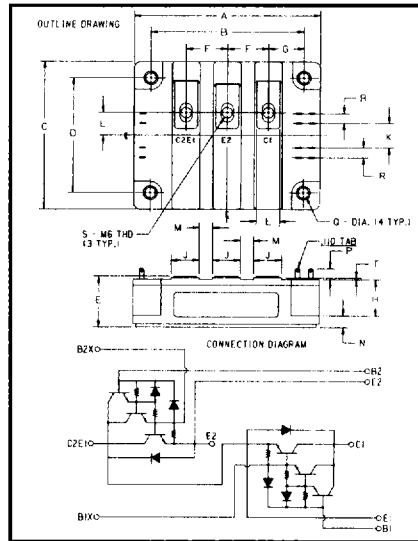

Dimension	Inches	Millimeters
A	4.449 Max.	113.0 Max.
B	3.661 ± 0.012	93.0 ± 0.3
C	3.543 Max.	90.0 Max.
D	2.756 ± 0.012	70.0 ± 0.3
E	1.22 Max.	31.0 Max.
F	0.984	25.0
G	0.846	21.5
H	0.827	21.0
J	0.669	17.0
K	0.591	15.0
L	0.551	14.0
M	0.315	8.0
N	0.276	7.0
P	0.256 Min.	6.5 Min.
Q	0.256 Dia.	6.5 Dia.
R	0.236	6.0
S	M6 Metric	M6
T	0.039	1.0

KD621K20, KD621220

D36

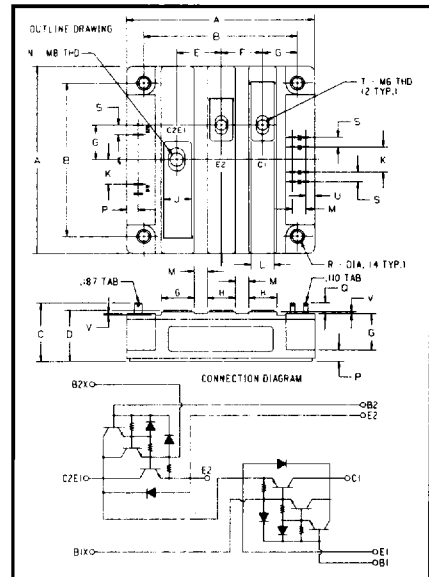

Dimension	Inches	Millimeters
A	4.488	114.0
B	3.661 ± 0.012	93.0 ± 0.3
C	1.358	34.5
D	1.22 Max.	31.0 Max.
E	1.063	27.0
F	0.984	25.0
G	0.827	21.0
H	0.669	17.0
J	0.63	16.0
K	0.591	15.0
L	0.551	14.0
M	0.315	8.0
N	M8 Metric	M8
P	0.276	7.0
Q	0.256 Min.	6.5 Min.
R	0.256 Dia.	6.5 Dia.
S	0.236	6.0
T	M6 Metric	M6
U	0.216	5.5
V	0.039	1.0

KD621K30, KD621230

D37

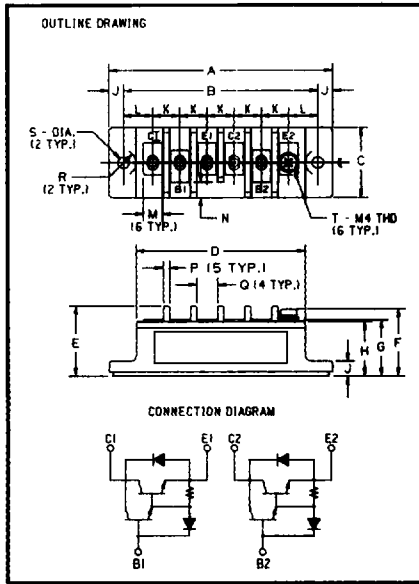

Dimension	Inches	Millimeters
A	4.213	107.0
B	3.661	93.0
C	1.339	34.0
D	3.189	81.0
E	1.319	33.5
F	1.26 Max.	32.0 Max.
G	1.063	27.0
H	1.024	26.0
J	0.276	7.0
K	0.512	13.0
L	0.551	14.0
M	0.354	9.0
N	0.295	7.5
P	0.118	3.0
Q	0.394	10.0
R	0.236 Rad.	6.0 Rad.
S	0.216 Dia.	5.5 Dia.
T	M4 Metric	M4

KT524575

D38

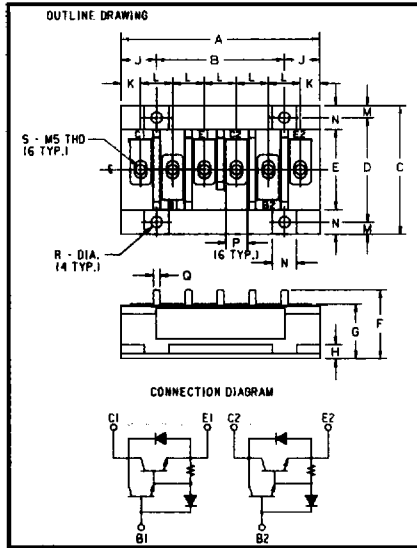

Dimension	Inches	Millimeters
A	3.858 ± 0.016	98.0 ± 0.4
B	2.48 ± 0.012	63.0 ± 0.3
C	2.52 ± 0.016	64.0 ± 0.4
D	2.047 ± 0.012	52.0 ± 0.3
E	1.575 ± 0.012	40.0 ± 0.3
F	1.339 Max.	34.0 Max.
G	1.063 +0.02/-0.0	27.0 +0.5/-0.0
H	0.276	7.0
J	0.689	17.5
K	0.374	9.5
L	0.662	15.8
M	0.236	6.0
N	0.472	12.0
P	0.413 ± 0.008	10.5 ± 0.2
Q	0.134	3.4
R	0.216 ± 0.006 Dia.	5.5 ± 0.15 Dia.
S	M5 Metric	M5

KT224510, KT224515

D39

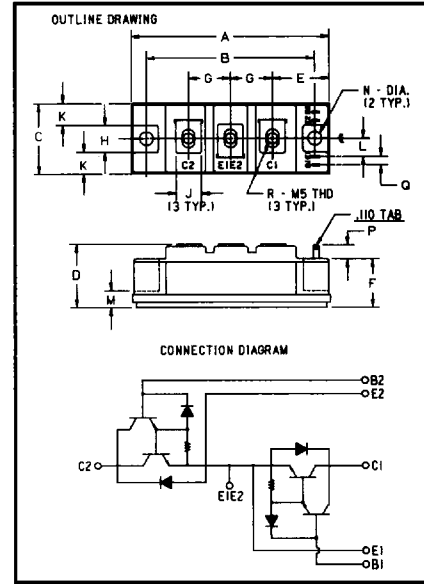

Dimension	Inches	Millimeters
A	3.701 Max.	94 Max.
B	3.150 ± 0.01	80.0 ± 0.25
C	1.339 Max.	34.0 Max.
D	1.181 Max.	30.0 Max.
E	1.063	27.0
F	0.906	23.0
G	0.787	20.0
H	0.512	13.0
J	0.472	12.0
K	0.413	10.5
L	0.344	8.75
M	0.315	8.0
N	0.256 Dia.	6.5 Dia.
P	0.256 Min.	6.5 Min.
Q	0.157	4.0
R	M5 Metric	M5

KC224503, KC224505, KC224575

D40

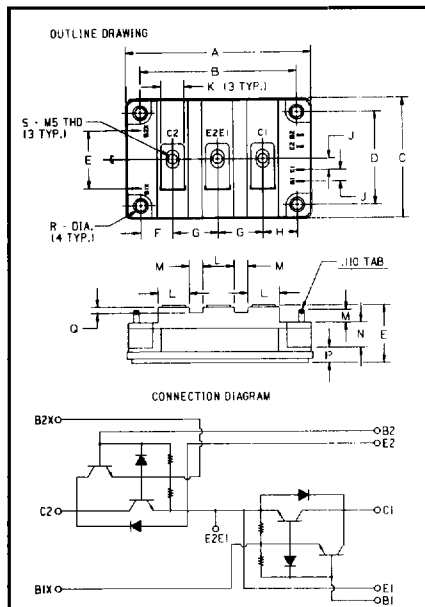

Dimension	Inches	Millimeters
A	3.74 Max.	95.0 Max.
B	3.15 ± 0.01	80.0 ± 0.25
C	2.441 Max.	62.0 Max.
D	1.89 ± 0.01	48.0 ± 0.25
E	1.181 Max.	30.0 Max.
F	0.65	16.5
G	0.906	23.0
H	0.689	17.5
J	0.236	6.0
K	0.472	12.0
L	0.630	16.0
M	0.276	7.0
N	0.512	13.0
P	0.315	8.0
Q	0.118	3.0
R	0.216 Dia.	5.5 Dia.
S	M5 Metric	M5

KC324510, KC324515

D41

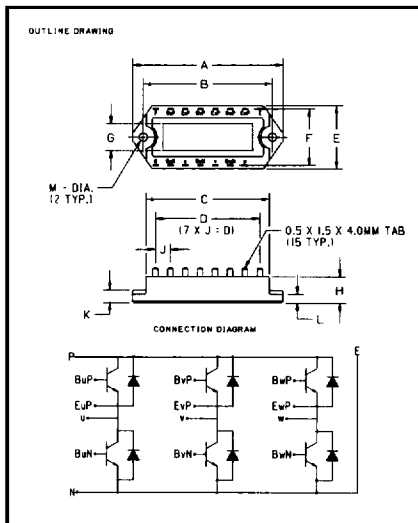

Dimension	Inches	Millimeters
A	3.031	77.0
B	2.598 ± 0.006	66.0 ± 0.15
C	2.48	63.0
D	2.1	53.34
E	1.287	32.7
F	1.15	29.2
G	0.551	14.0
H	0.531	13.5
J	0.3	7.62
K	0.256	6.5
L	0.177	4.5
M	0.169 ± 0.004 Dia.	4.3 ± 0.1 Dia.

KEE24501

Note: Each transistor symbol represents a Darlington Transistor with base emitter resistors on each stage and a base emitter speed up diode on the input stage.

D42

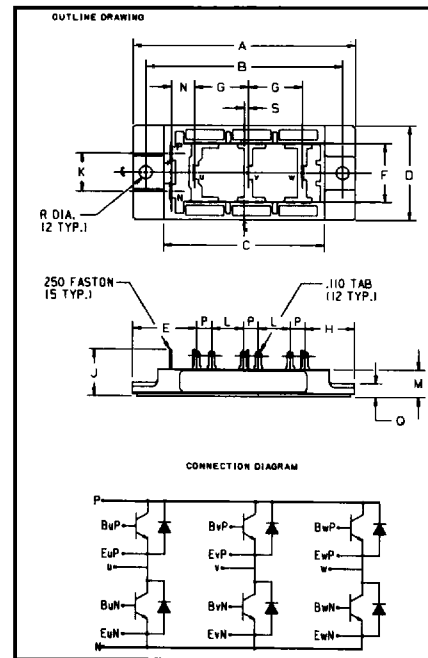

Dimension	Inches	Millimeters
A	4.134	105.0
B	3.661 ± 0.008	93.0 ± 0.2
C	2.992	76.0
D	1.772	45.0
E	1.201	30.5
F	1.102	28.0
G	1.004	25.5
H	0.925	23.5
J	0.884	22.45
K	0.709	18.0
L	0.591	15.0
M	0.512	13.0
N	0.433	11.0
P	0.276	7.0
Q	0.256	6.5
R	0.216 ± 0.004 Dia.	5.5 ± 0.1 Dia.
S	0.079	2.0

KED24501, KED245A1, KED24502

Note: Each transistor symbol represents a Darlington Transistor with base emitter resistors on each stage and a base emitter speed up diode on the input stage.

D43

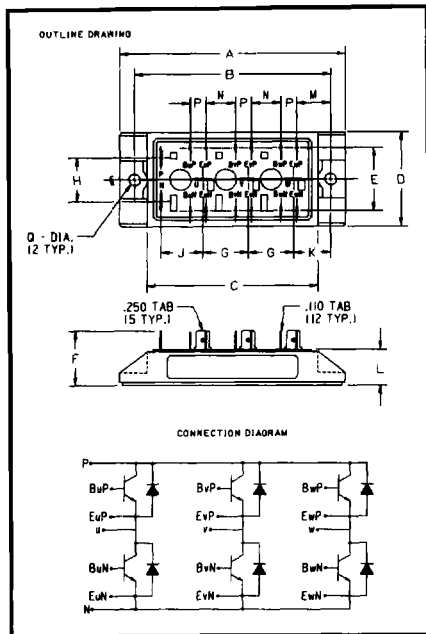

Dimension	Inches	Millimeters
A	4.212	107.0
B	3.661 ± 0.012	93.0 ± 0.3
C	3.189	81.0
D	1.772	45.0
E	1.181	30.0
F	1.024	26.0
G	0.846	21.5
H	0.827	21.0
J	0.787	20.0
K	0.689	17.5
L	0.669 ± 0.02	17.0 ± 0.5
M	0.63	16.0
N	0.551	14.0
P	0.295	7.5
Q	0.216 Dia.	5.5 Dia.

KE721KA1, KE7212A1

Note: Each transistor symbol represents a Triple Darlington Transistor with base emitter resistors on each stage and base emitter speed up diodes on the input stages.

D44

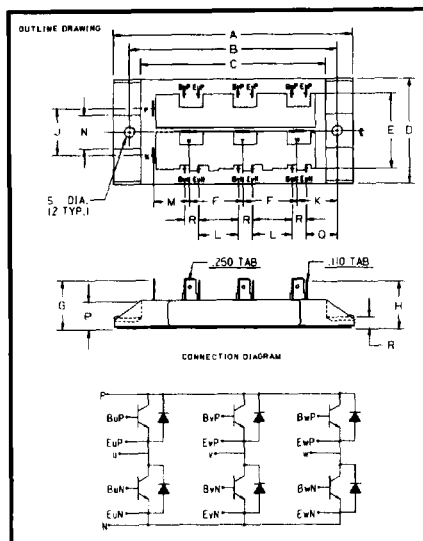

Dimension	Inches	Millimeters
A	5.0	127.0
B	4.331 ± 0.012	110.0 ± 0.3
C	3.858	98.0
D	2.205	56.0
E	1.575	40.0
F	1.122	28.5
G	1.043	26.5
H	1.008	25.6
J	0.984	25.0
K	0.846	21.5
L	0.827	21.0
M	0.748	19.0
N	0.709	18.0
P	0.689	17.5
Q	0.65	16.5
R	0.295	7.5
S	0.21 Dia.	5.5 Dia.

KE721K03, KE721203

Note: Each transistor symbol represents a Triple Darlington Transistor with base emitter resistors on each stage and base emitter speed up diodes on the input stages.

D45

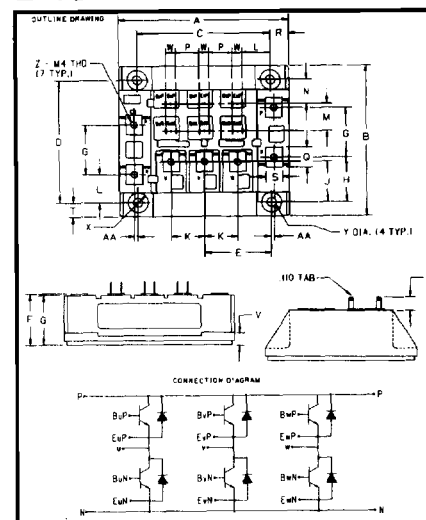

Dimension	Inches	Millimeters
A	4.02 ± 0.02	102.0 ± 0.5
B	3.58 ± 0.02	91.0 ± 0.5
C	3.15 ± 0.01	80.0 ± 0.25
D	2.913 ± 0.1	74.0 ± 0.25
E	1.57	40.0
F	1.26 Max.	32.0 Max.
G	1.18	30.0
H	1.06	27.0
J	0.96	24.5
K	0.79	20.0
L	0.67	17.0
M	0.65	16.5
N	0.57	14.5
P	0.55	14.0
Q	0.47	12.0
R	0.43	11.0
S	0.39	10.0
T	0.33	8.5
U	0.32	8.1
V	0.3	7.5
W	0.24	6.0
X	0.24 Rad.	6.0 Rad.
Y	0.216 Dia.	5.5 Dia.
Z	M4 Metric	M4
AA	0.08	2.0

KE921K05, KE921205

Note: Each transistor symbol represents a Triple Darlington Transistor with base emitter resistors on each stage and base emitter speed up diodes on the input stages.

D46

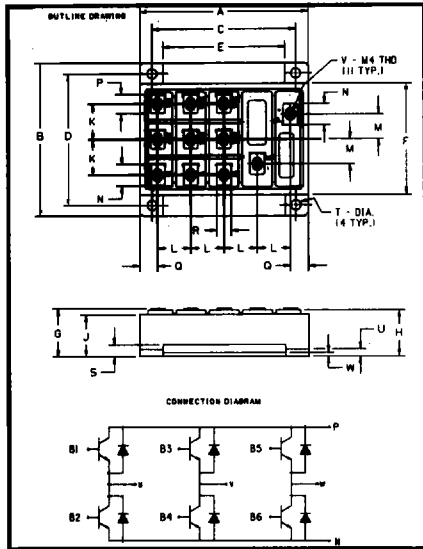

Dimension	Inches	Millimeters
A	3.701	94.0
B	3.386	86.0
C	3.150 ± 0.01	80.0 ± 0.25
D	2.913 ± 0.01	74.0 ± 0.25
E	2.677	68.0
F	2.461	62.5
G	1.063 ± 0.016	27.0 ± 0.4
H	1.024	26.0
J	0.925	23.5
K	0.787	20.0
L	0.728	18.5
M	0.551	14.0
N	0.472	12.0
P	0.413	10.5
Q	0.394	10.0
R	0.315	8.0
S	0.256	6.5
T	0.212 ± 0.004 Dia.	5.4 ± 0.1 Dia.
U	0.157	4.0
V	M4 Metric	M4
W	0.079	2.0

KE524505, KE524510, KE524575

Note: Each transistor symbol represents a Darlington Transistor with base emitter resistors on each stage and a base emitter speed up diode on the input stage.

D47

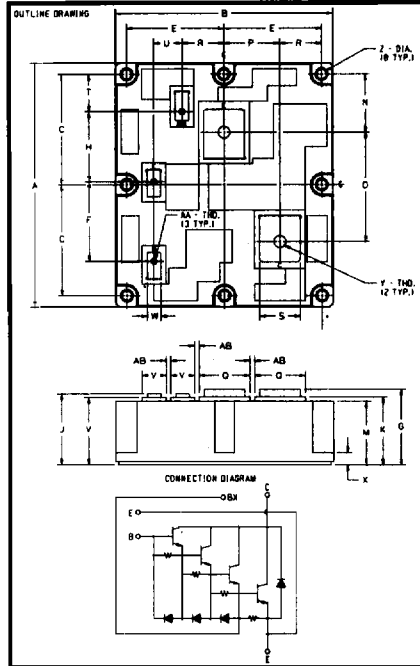

Dimension	Inches	Millimeters
A	6.42 Max.	163.0 Max.
B	5.71 Max.	145.0 Max.
C	2.913 ± 0.01	74.0 ± 0.25
D	2.559 ± 0.01	65.0 ± 0.25
E	2.01	51.0
F	2.87	73.0
G	1.85	47.0
H	1.54	39.0
J	1.97 Max.	50.0 Max.
K1	1.85 Max.	47.0 Max.
K2	1.75	44.5
L	0.98	25.0
M	1.34	34.0
N	1.10	28.0
P	0.75	19.0
Q	1.06	27.0
R	0.63	16.0
S	1.46	37.0
T	0.35	9.0
U	0.31	8.0
V	M8 Metric	M8
W	1.77	45.0
X	1.65	42.0
Y	0.12	3.0
Z	M6 Metric	M6

KS62121KHB

D48

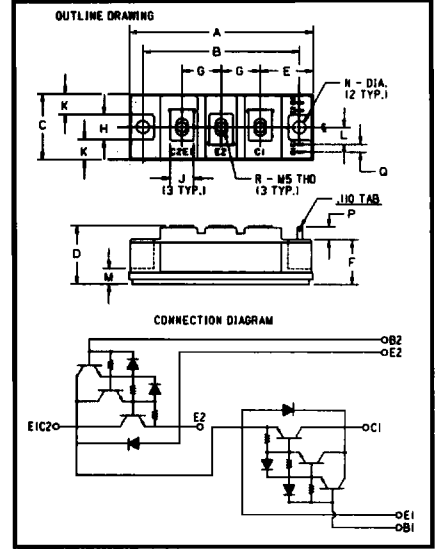

Dimension	Inches	Millimeters
A	3.701 Max.	94.0 Max.
B	3.150 ± 0.01	80.0 ± 0.25
C	1.339 Max.	34.0 Max.
D	1.181 Max.	30.0 Max.
E	1.063	27.0
F	0.906	23.0
G	0.787	20.0
H	0.512	13.0
J	0.472	12.0
K	0.413	10.5
L	0.344	8.75
M	0.315	8.0
N	0.256 Dia.	6.5 Dia.
P	0.256 Min.	6.5 Min.
Q	0.157	4.0
R	M5 Metric	M5

KD224503HB, KD224505HB

D49

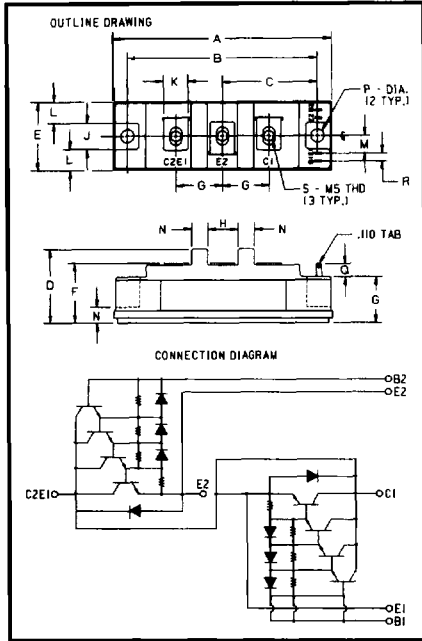

Dimension	Inches	Millimeters
A	4.25 Max.	108.0 Max.
B	3.661 ± 0.012	93.0 ± 0.3
C	1.83	46.5
D	1.46	37.0
E	1.34 Max.	34.0 Max.
F	1.18 Max.	30.0 Max.
G	0.9	23.0
H	0.59	15.0
J	0.51	13.0
K	0.47	12.0
L	0.41	10.5
M	0.344	8.75
N	0.31	8.0
P	0.356 Dia.	6.5 Dia.
Q	0.25 Min.	6.5 Min.
R	0.16	4.0
S	M5 Metric	M5

KD221K05HB, KD221205HB

D50

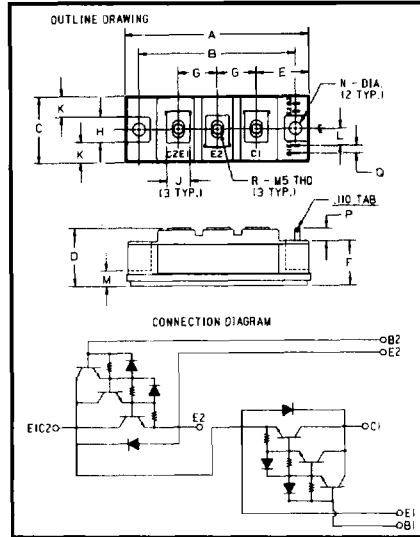

Dimension Inches Millimeters

A	3.701 Max.	94.0 Max.
B	3.150 ± 0.01	80.0 ± 0.25
C	1.339 Max.	34.0 Max.
D	1.181 Max.	30.0 Max.
E	1.063	27.0
F	0.906	23.0
G	0.787	20.0
H	0.512	13.0
J	0.472	12.0
K	0.413	10.5
L	0.344	8.75
M	0.315	8.0
N	0.256 Dia.	6.5 Dia.
P	0.256 Min.	6.5 Min.
Q	0.157	4.0
R	M5 Metric	M5

KD224575HB

D51

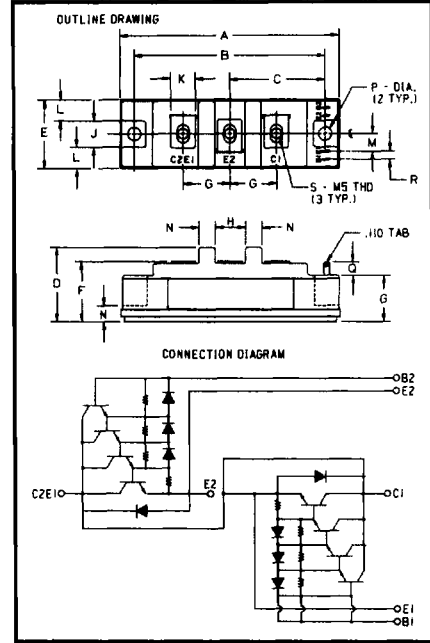

Dimension Inches Millimeters

A	4.25 Max.	108.0 Max.
B	3.661 ± 0.012	93.0 ± 0.3
C	1.83	46.5
D	1.46	37.0
E	1.34 Max.	34.0 Max.
F	1.18 Max.	30.0 Max.
G	0.9	23.0
H	0.59	15.0
J	0.51	13.0
K	0.47	12.0
L	0.41	10.5
M	0.344	8.75
N	0.31	8.0
P	0.256 Dia.	6.5 Dia.
Q	0.25 Min.	6.5 Min.
R	0.16	4.0
S	M5 Metric	M5

KD221K75HB, KD221275HB

D52

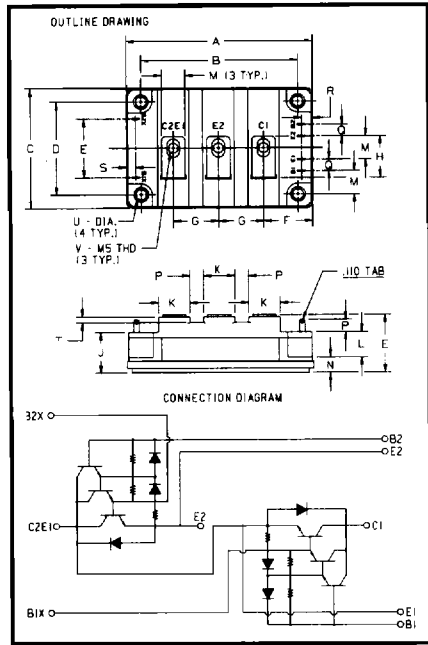

Dimension	Inches	Millimeters
A	3.74	95.0
B	3.150 ± 0.01	80.0 ± 0.25
C	2.44	62.0
D	1.890 ± 0.01	48.0 ± 0.25
E	1.18	30.0
F	0.98	25.0
G	0.91	23.0
H	0.85	21.5
J	0.83	21.0
K	0.63	16.0
L	0.51	13.0
M	0.47	12.0
N	0.31	8.0
P	0.28	7.0
Q	0.24	6.0
R	0.20	5.0
S	0.16	4.0
T	0.12	3.0
U	0.216 ± 0.004 Dia.	5.5 ± 0.1 Dia.
V	M5 Metric	M5

KD324510HB, KD324515HB

D53

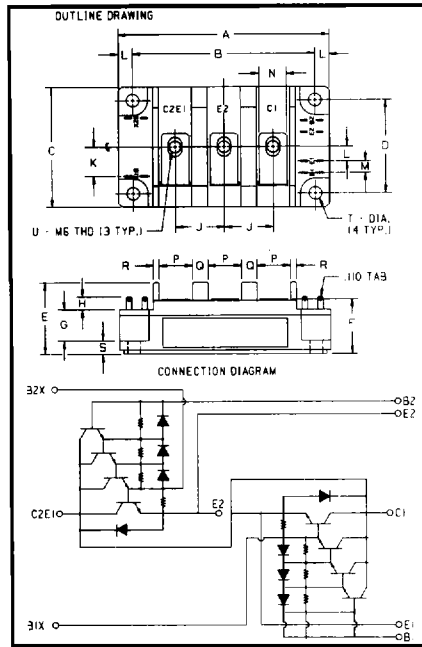

Dimension	Inches	Millimeters
A	4.25	108.0
B	3.661 ± 0.012	93.0 ± 0.3
C	2.44 Max.	62.0 Max.
D	1.890 ± 0.012	48.0 ± 0.3
E	1.46	37.0
F	1.18 Max.	30.0 Max.
G	0.63	16.0
H	0.25 Min.	6.5 Min.
J	0.98	25.0
K	0.59	15.0
L	0.30	7.5
M	0.24	6.0
N	0.55	14.0
P	0.67	17.0
Q	0.31	8.0
R	0.12	3.0
S	0.28	7.0
T	0.256 Dia.	6.5 Dia.
U	M6 Metric	M6

**KD421K10HB, KD421210HB,
 KD421K15HB, KD421215HB**

D54

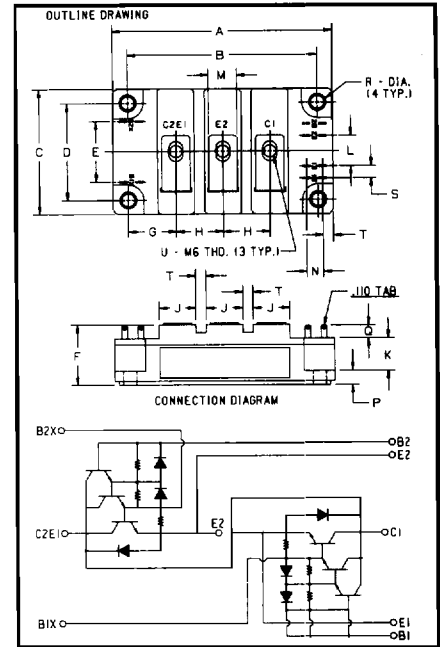

Dimension	Inches	Millimeters
A	4.25	108.0 Max.
B	3.661 ± 0.01	93.0 ± 0.25
C	2.44 Max.	62.0 Max.
D	1.89 ± 0.01	48.0 ± 0.25
E	1.18	30.0
F	1.18 Max.	30.0 Max.
G	0.92	23.5
H	0.9 Min.	23.0
J	0.71	18.0
K	0.63	16.0
L	0.59	15.0
M	0.55	14.0
N	0.31	8.0
P	0.28	7.0
Q	0.25 Min.	6.5 Min.
R	0.356 Dia.	6.5 Dia.
S	0.24	6.0
T	0.2	5.0
U	M6 Metric	M6

KD424520HB

D55

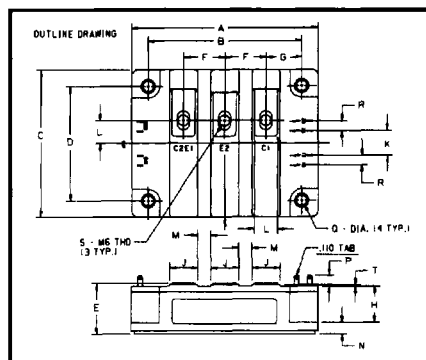

Dimension	Inches	Millimeters
A	4.449 Max.	113.0 Max.
B	3.661 ± 0.012	93.0 ± 0.3
C	3.543 Max.	90.0 Max.
D	2.756 ± 0.012	70.0 ± 0.3
E	1.22 Max.	31.0 Max.
F	0.984	25.0
G	0.846	21.5
H	0.827	21.0
J	0.669	17.0
K	0.591	15.0
L	0.551	14.0
M	0.315	8.0
N	0.276	7.0
P	0.256 Min.	6.5 Min.
Q	0.256 Dia.	6.5 Dia.
R	0.236	6.0
S	M6 Metric	M6
T	0.039	1.0

KD621K20HB, KD621220HB

D56

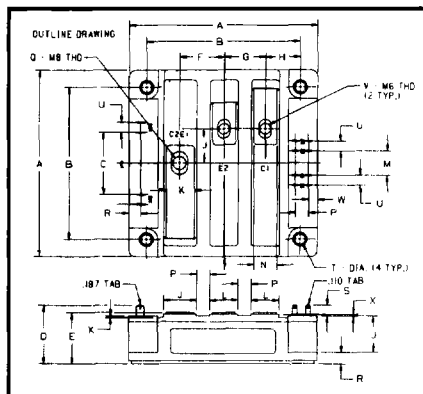

Dimension	Inches	Millimeters
A	4.488	114.0
B	3.661 ± 0.012	93.0 ± 0.3
C	1.358	34.5
D	1.22 Max.	31.0 Max.
E	1.063	27.0
F	0.984	25.0
G	0.827	21.0
H	0.669	17.0
J	0.63	16.0
K	0.591	15.0
L	0.551	14.0
M	0.315	8.0
N	M8 Metric	M8
P	0.276	7.0
Q	0.256 Min.	6.5 Min.
R	0.256 Dia.	6.5 Dia.
S	0.236	6.0
T	M6 Metric	M6
U	0.216	5.5
V	0.039	1.0

KD621K30HB, KD621230HB

D57

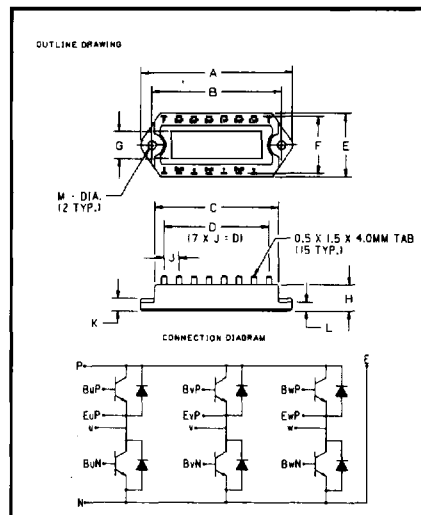

Dimension	Inches	Millimeters
A	3.031	77.0
B	2.598 ± 0.006	66.0 ± 0.15
C	2.48	63.0
D	2.1	53.34
E	1.287	32.7
F	1.15	29.2
G	0.551	14.0
H	0.531	13.5
J	0.3	7.62
K	0.256	6.5
L	0.177	4.5
M	0.169 ± 0.004 Dia.	4.3 ± 0.1 Dia.

KEE24501HB

Note: Each transistor symbol represents a Darlington Transistor with base emitter resistors on each stage and a base emitter speed up diode on the input stage.

D58

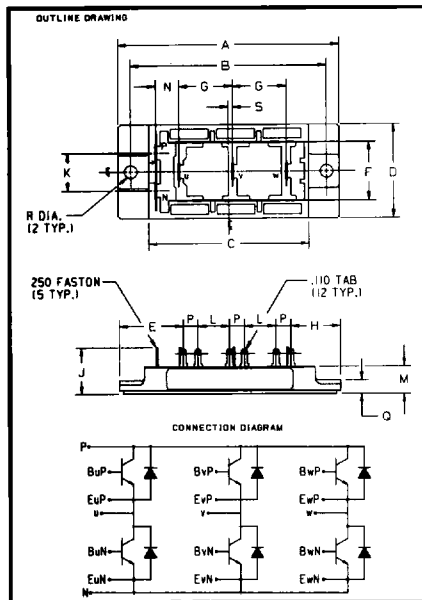

Dimension	Inches	Millimeters
A	4.134	105.0
B	3.661 ± 0.008	93.0 ± 0.2
C	2.992	76.0
D	1.772	45.0
E	1.201	30.5
F	1.102	28.0
G	1.004	25.5
H	0.925	23.5
J	0.884	22.45
K	0.709	18.0
L	0.591	15.0
M	0.512	13.0
N	0.433	11.0
P	0.276	7.0
Q	0.256	6.5
R	0.216 ± 0.004 Dia.	5.5 ± 0.1 Dia.
S	0.079	2.0

KED245A1HB

Note: Each transistor symbol represents a Darlington Transistor with base emitter resistors on each stage and a base emitter speed up diode on the input stage.

D59

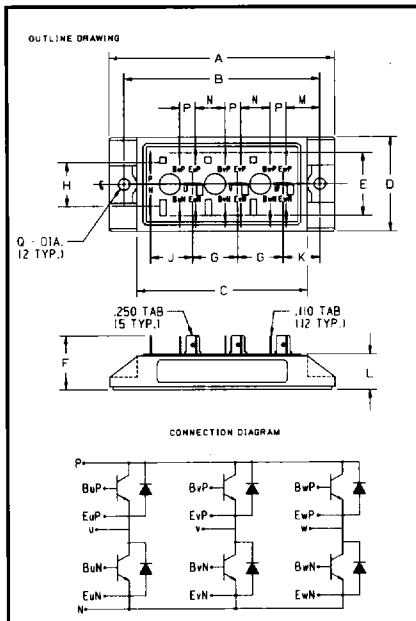

Dimension	Inches	Millimeters
A	4.21	107.0
B	3.661 ± 0.012	93.0 ± 0.3
C	3.19	81.0
D	1.77	45.0
E	1.18	30.0
F	1.02	26.0
G	0.85	21.5
H	0.83	21.0
J	0.79	20.0
K	0.69	17.5
L	0.669 ± 0.02	17.0 ± 0.5
M	0.63	16.0
N	0.55	14.0
P	0.3	7.5
Q	0.216 Dia.	5.5 Dia.

KE721KA1HB, KE7212A1HB

D60

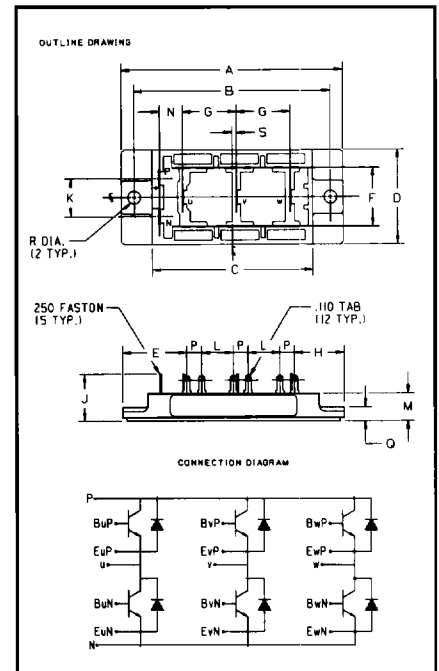

Dimension	Inches	Millimeters
A	4.134	105.0
B	3.661 ± 0.008	93.0 ± 0.2
C	2.992	76.0
D	1.772	45.0
E	1.201	30.5
F	1.102	28.0
G	1.004	25.5
H	0.925	23.5
J	0.884	22.45
K	0.709	18.0
L	0.591	15.0
M	0.512	13.0
N	0.433	11.0
P	0.276	7.0
Q	0.256	6.5
R	0.216 ± 0.004 Dia.	5.5 ± 0.1 Dia.
S	0.079	2.0

KED24502HB

Note: Each transistor symbol represents a Darlington Transistor with base emitter resistors on each stage and a base emitter speed up diode on the input stage.

D61

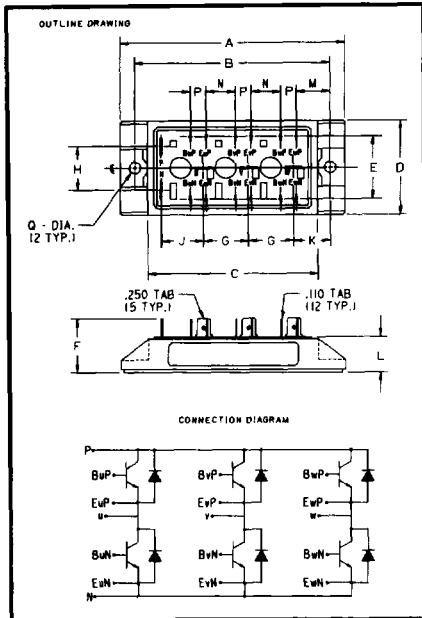

Dimension	Inches	Millimeters
A	4.212	107.0
B	3.661 ± 0.012	93.0 ± 0.3
C	3.189	81.0
D	1.772	45.0
E	1.181	30.0
F	1.024	26.0
G	0.846	21.5
H	0.827	21.0
J	0.787	20.0
K	0.689	17.5
L	0.669 ± 0.02	17.0 ± 0.5
M	0.63	16.0
N	0.551	14.0
P	0.295	7.5
Q	0.216 Dia.	5.5 Dia.

KEF24503HB

Note: Each transistor symbol represents a Darlington Transistor with base emitter resistors on each stage and a base emitter speed up diode on the input stage.

D62

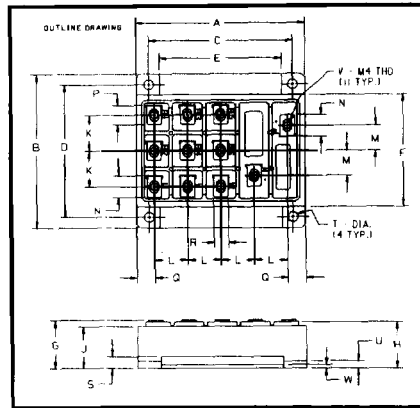

Dimension	Inches	Millimeters
A	3.071	94.0
B	3.386	86.0
C	3.150 ± 0.01	80.0 ± 0.25
D	2.913 ± 0.01	74.0 ± 0.25
E	2.677	68.0
F	2.461	62.5
G	1.063 ± 0.016	27.0 ± 0.4
H	1.024	26.0
J	0.925	23.5
K	0.787	20.0
L	0.728	18.5
M	0.551	14.0
N	0.472	12.0
P	0.413	10.5
Q	0.394	10.0
R	0.315	8.0
S	0.256	6.5
T	0.212 ± 0.004 Dia.	5.4 ± 0.1 Dia.
U	0.157	4.0
V	M4 Metric	M4
W	0.079	2.0

KE524503HB, KE524505HB, KE524575HB, KE524510HB

Note: Each transistor symbol represents a Darlington Transistor with base emitter resistors on each stage and a base emitter speed up diode on the input stage.

D63

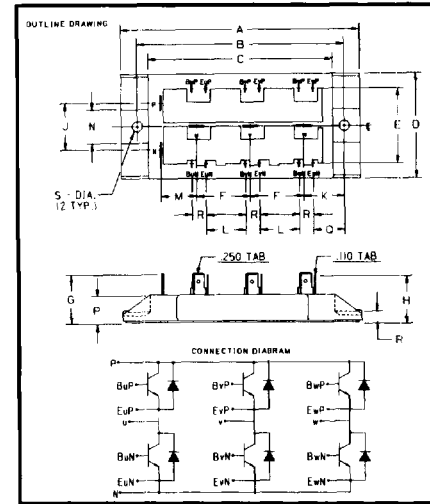

Dimension	Inches	Millimeters
A	5.0	127.0
B	4.331 ± 0.012	110.0 ± 0.3
C	3.858	98.0
D	2.205	56.0
E	1.575	40.0
F	1.122	28.5
G	1.043	26.5
H	1.008	25.6
J	0.984	25.0
K	0.846	21.5
L	0.827	21.0
M	0.748	19.0
N	0.709	18.0
P	0.689	17.5
Q	0.650	16.5
R	0.295	7.5
S	0.216 Dia.	5.5 Dia.

KE721K03HB, KE721203HB

D64

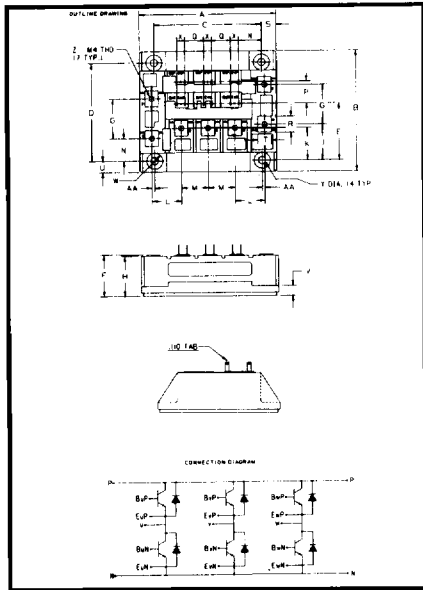

Dimension	Inches	Millimeters
A	4.02 ± 0.02	102.0 ± 0.5
B	3.58 ± 0.02	91.0 ± 0.5
C	3.15 ± 0.01	80.0 ± 0.25
D	2.913 ± 0.01	74.0 ± 0.25
E	1.169	43.0
F	1.24 Max.	31.5 Max.
G	1.18	30.0
H	1.16	29.5
J	1.06	27.0
K	0.96	24.5
L	0.87	22.0
M	0.79	20.0
N	0.67	17.0
P	0.65	16.5
Q	0.55	14.0
R	0.47	12.0
S	0.43	11.0
T	0.39	10.0
U	0.33	8.5
V	0.28	7.0
W	0.24 Rad.	6.0 Rad.
X	0.24	6.0
Y	0.216 Dia.	5.5 Dia.
Z	M4 Metric	M4
AA	0.08	2.0

KET24505HB

D65

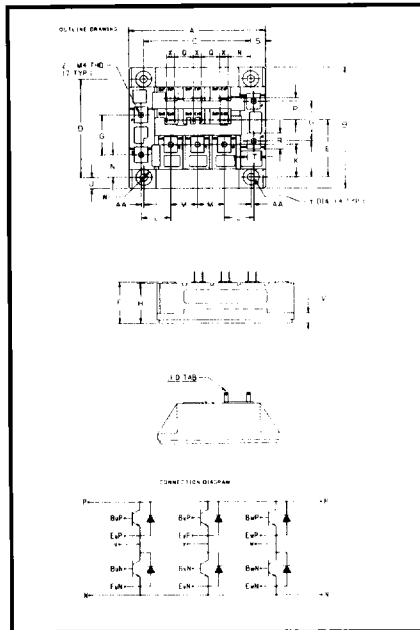

Dimension	Inches	Millimeters
A	4.02 ± 0.2	102.0 ± 0.5
B	3.58 ± 0.02	91.0 ± 0.5
C	3.15 ± 0.01	80.0 ± 0.25
D	2.913 ± 0.01	74.0 ± 0.25
E	1.69	43.0
F	1.24 Max.	31.5 Max.
G	1.18	30.0
H	1.16	29.5
J	1.06	27.0
K	0.96	24.5
L	0.87	22.0
M	0.79	20.0
N	0.67	17.0
P	0.65	16.5
Q	0.55	14.0
R	0.47	12.0
S	0.43	11.0
T	0.39	10.0
U	0.33	8.5
V	0.28	7.0
W	0.24 Rad.	6.0 Rad.
X	0.24	6.0
Y	0.216 Dia.	5.5 Dia.
Z	M4 Metric	M4
AA	0.08	2.0

KE921205HB

D66

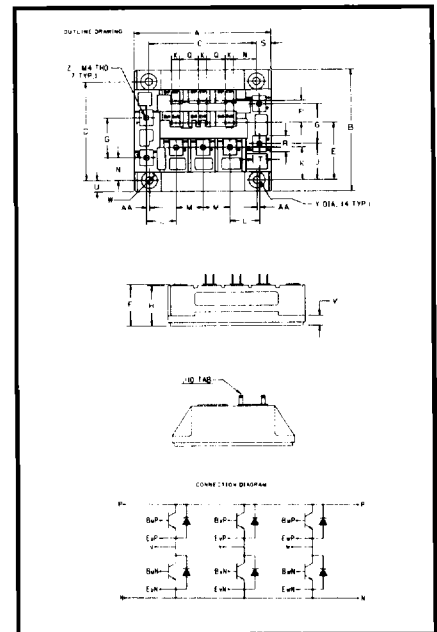

Dimension	Inches	Millimeters
A	4.02 ± 0.02	102.0 ± 0.5
B	3.58 ± 0.2	91.0 ± 0.5
C	3.15 ± 0.01	80.0 ± 0.025
D	2.913 ± 0.01	74.0 ± 0.25
E	1.69	43.0
F	1.24 Max.	31.5 Max.
G	1.18	30.0
H	1.16	29.5
J	1.06	27.0
K	0.96	24.5
L	0.87	22.0
M	0.79	20.0
N	0.67	17.0
P	0.65	16.5
Q	0.55	14.0
R	0.47	12.0
S	0.43	11.0
T	0.39	10.0
U	0.33	8.5
V	0.28	7.0
W	0.24 Rad.	6.0 Rad.
X	0.24	6.0
Y	0.216 Dia.	5.55 Dia.
Z	M4 Metric	M4
AA	0.08	2.0

KET24575HB

D67

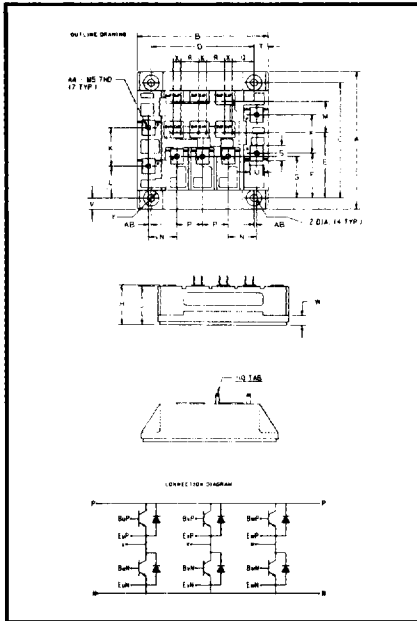

Dimension	Inches	Millimeters
A	4.21 ± 0.02	107.0 ± 0.5
B	4.02 ± 0.02	102.0 ± 0.5
C	3.543 ± 0.01	90.0 ± 0.25
D	3.15 ± 0.01	80.0 ± 0.25
E	2.01	51.0
F	1.38	35.0
G	1.28	32.5
H	1.26 Max.	32.0 Max.
J	1.20	30.5
K	1.18	30.0
L	0.98	25.0
M	0.96	24.5
N	0.87	22.0
P	0.79	20.0
Q	0.67	17.0
R	0.55	14.0
S	0.47	12.0
T	0.43	11.0
U	0.39	10.0
V	0.33	8.5
W	0.31	8.0
X	0.24	6.0
Y	0.24 Rad.	6.0 Rad.
Z	0.216 Dia.	5.5 Dia.
AA	M5 Metric	M5
AB	0.08	2.0

KET24510HB