

Potentiometric Setting and Sensing Devices

- 7/8" (22 mm) Industrial Single Turn Bushing Mount
- Wirewound metric size
- R22W 320 ° with endstop, R22WC 360 ° without stop
- Electrical angle 320 °, 270 ° available
- High resolution
- Rear shaft extension, gang versions

R22W/WC

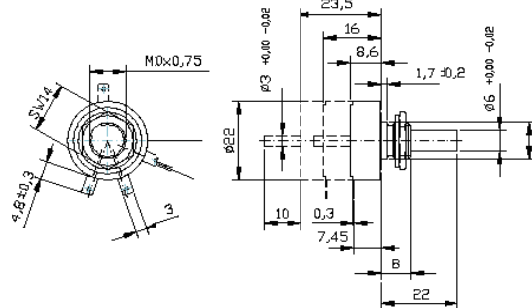
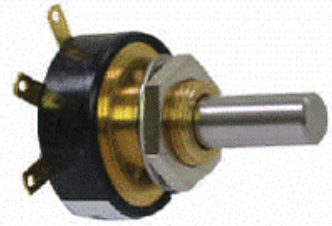

All dimensions in mm

ELECTRICAL CHARACTERISTICS

Resistance element	Wirewound
Standard resistance values (Ω)	100, 500, 1k, 2k, 5k, 10k
Standard resistance tolerance (%)	(typ. IEC 60393) ± 5
Best possible linearity tolerance (%)	(typ. IEC 60393) ± 0.5
Standard linearity tolerance (%)	(typ. IEC 60393) ± 1
Type of linearity	Independent linearity
Power Rating (+70°C)	1.5 Watt
Electrical travel	320 ° ± 5° (optional 270°)
Insulation resistance	1000 MOhm at 1000 VDC
Dielectric strength	1000 VAC
Noise	<100 Ohm ENR

MECHANICAL CHARACTERISTICS

Mechanical angle (R22WC)	360° continuous
Mechanical angle (R22W)	320 ° ± 5° with endstops
Torque starting / running (Ncm)	0.5 / 0.3
Shaft diameter	6 mm
Shaft length	22 mm (FMS)
Rotational life (shaft revolutions)	(typ. IEC60939) 400.000
Bearing type	sleeve
Operating temperature (°C)	-50°C to +125°C

APPLICATION

These controls are designed for manual operations as preset and panel trimmers or semi - sensors. A good price / performance ratio, exact resistance and linearity tolerance makes it suitable for a wide range of industrial applications - setting device, switch cabinet control, coarse position sensor, robust angle sensor.

ORDERING INFORMATION

R22W / WC	10k	L1%	B	D	RA	2C	SL25	CT
Model	Ω	Linearity	Screw driver slot	O ring	rear shaft extn.	Sections	Special Shaft	Center tap

European Sales & Technical Support

MegAuto KG
 Am Tummelsgrund 48
 D 01156 Dresden, Germany
 Tel : +49 351 6587894 0 Fax : +49 351 6587894 9
 Email : info@megauto.de / www.megauto.de
 a MegAuto Group Company

Worldwide Technical & Marketing Center

MegAuto International
 Div of **CONSENSE SENSALL ELECTRONICS PVT LTD.**
 32, Electronic Sadan - I, MIDC, Bhosari, Pune - 411026, INDIA
 Tel : +91 20 30681190 , +91 20 30626126
 Email : mail@megacraft.net / www.sensall.info
 a MegAuto Group Company



Please note: The specification and information in this datasheet cannot consider all special demands that are caused by the application. Because of this, there are no general description of the properties of the product. Megacraft does not assume any responsibility for damages due to improper application of our products. The user has to ensure by its own, that the products used are suitable for his application. Megacraft does not warrant the reproducibility of published applications.